

SERVICE MANUAL



T 755

Surround Sound Receiver

T 755

Surround Sound
Receiver

SAFETY INFORMATION

NAD[®], Soft Clipping[™], PowerDrive[™] and EARS[™] are trademarks of NAD Electronics International, a division of Lenbrook Industries Limited.
©NAD All Rights Reserved



Manufactured under license under U.S. Patent #'s: 5,451,942; 5,956,674; 5,974,380; 5,978,762; 6,226,616; 6,487,535; 7,003,467; 7,212,872 & other U.S. and worldwide patents issued & pending. DTS is a registered trademark & the DTS logos and Symbol are trademarks of DTS, Inc. © 1996-2007 DTS, Inc. All Rights Reserved.

Manufactured under license from Dolby Laboratories. "Dolby", "Pro Logic", and the double-D symbol are trademarks of Dolby Laboratories.

THIS DEVICE COMPLIES WITH PART 15 OF THE FCC RULES. OPERATION IS SUBJECT TO THE FOLLOWING TWO CONDITIONS:
(1) THIS DEVICE MAY NOT CAUSE HARMFUL INTERFERENCE.
(2) THIS DEVICE MUST ACCEPT INTERFERENCE RECEIVED, INCLUDING INTERFERENCE THAT MAY CAUSE UNDESIRABLE OPERATION.

NAD ELECTRONICS INTERNATIONAL
633 GRANITE COURT, PICKERING, ON, CANADA L1W 3K1
MODEL T755 AV SURROUND SOUND RECEIVER
POWER RATING 120V ~ 60Hz 6A
DESIGNED & ENGINEERED IN CANADA, CUSTOM MANUFACTURED TO NAD SPECIFICATIONS IN CHINA

NAD ELECTRONICS INTERNATIONAL
MODEL T755 AV SURROUND SOUND RECEIVER
POWER RATING 230V ~ 50Hz 3A
DESIGNED & ENGINEERED IN CANADA, CUSTOM MANUFACTURED TO NAD SPECIFICATIONS IN CHINA

 **CAUTION** 
RISK OF ELECTRIC SHOCK
DO NOT OPEN
WARNING: SHOCK HAZARD - DO NOT OPEN
AVIS: RISQUE DE CHOC ELECTRIQUE - NE PAS OUVRIR

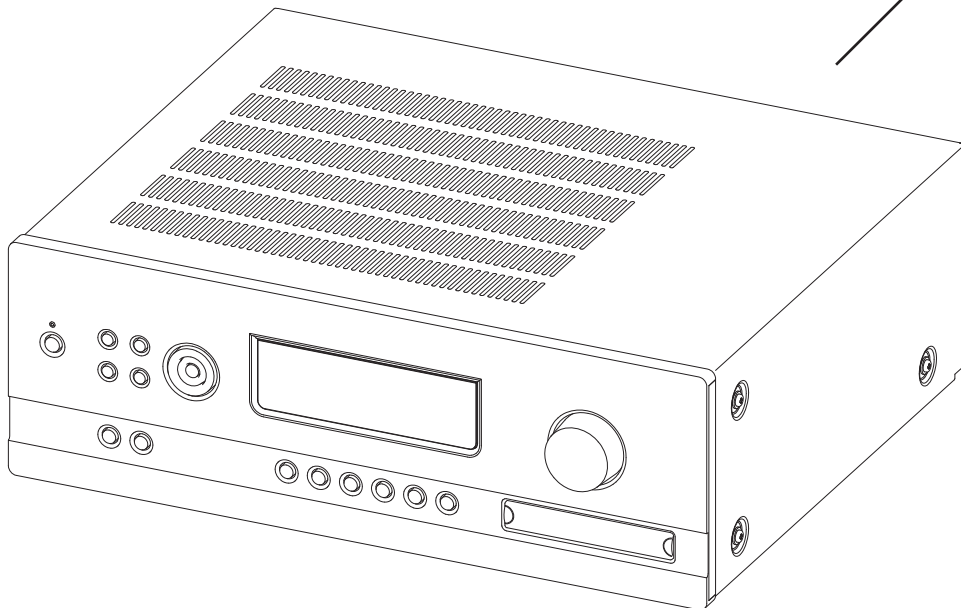

SERVICE SAFETY PRECAUTIONS

1. Replacing the fuses

CAUTION:

FOR CONTINUED PROTECTION AGAINST THE RISK OF FIRE REPLACE ONLY WITH SAME TYPE OF FUSE.

Reference Designator		Database Part Number	Description
F8001*AH	⚠	20-001-0072-90	FUSE TIME-LAG 6.3A 250VAC 5X20mm TSD UL/CSA/VDE/CCC WALTER
F8001*C,CT	⚠	20-001-0072-90	FUSE TIME-LAG 6.3A 250VAC 5X20mm TSD UL/CSA/VDE/CCC WALTER
F8002*AH	⚠	20-001-0076-90	FUSE 1.6A 250V TIME LAG LBC 5X20mm TSD
F8002*C,CT	⚠	20-001-0069-90	UL/CSA/VDE/SEMKO FUSE TIME-LAG 800mA 250V 5x20mm TSD UL/CSA/VDE/CCC WALTER 5X20mm VDE/UL/CSA 5T

NOTE:

- <*AH > : USA, CANADIAN MODEL ONLY.
- <*C, *CT > : EUROPEAN MODEL ONLY.

2. Safety check out

(Only U.S.A. model)

Parts marked with the symbol ⚠ are critical with regard to the risk of fire and electric shock.

CONTENTS

DESCRIPTION	PAGE
SPECIFICATIONS.....	4 - 5
REAR PANEL / FRONT PANEL VIEW	6
DISASSEMBLY INSTRUCTIONS	7
WIRING DIAGRAM	8 - 9
BLOCK DIAGRAM.....	10
SPECIAL FUNCTION	11
DETAILS & WAVEFORMS ON SYSTEM & TEST & DEBUGGING.....	11-12
ADJUSTMENT POINTS DIAGRAM / AMPLIFIER ADJUSTMENT	13
PCB LAYOUT.....	14- 28
SCHEMATIC DIAGRAM.....	29-47
ELECTRICAL PARTS LIST	48-67
IC BLOCK DIAGRAM	68-86
EXPLODED VIEW.....	87-88
EXPLODED VIEW PARTS LIST	89-91
SINGLE AMPLIFIER CHANNEL REPAIR KIT	92-93
PACKING DIAGRAM.....	94

SPECIFICATIONS

POWER AMPLIFIER SECTION

Rated distortion	(Rated power level into 8 ohms, THD 20 Hz-20 kHz FL/C/FR)	$\leq 0.1 \%$
	(Rated power level into 8 ohms, THD 20 Hz-20 kHz SL/SR)	$\leq 0.1 \%$
Input Sensitivity	(ref. 8 ohms, 1 kHz)	$1 \pm 0.1 \text{ V}$
S/N Ratio	(A-wtd, 1kHz, 1 W, 8 ohm, FL/C/FR/SL/SR)	$\geq -80 \text{ dB}$
Frequency Response	(20 Hz - 20 kHz)	$0 \pm 1.0 \text{ dB}$
Channel Balance	(1 dB to -40 dB, 1 kHz)	$\leq 2 \text{ dB}$
	(-41 dB to -50 dB, 1 kHz)	$\leq 3 \text{ dB}$
Audio muting at 1 kHz		$\geq 55 \text{ dB}$
Subwoofer out, 500 mV in	(THD at 2 V O/P, 100 Hz)	$\leq 0.5 \%$
Crosstalk	(500 mV input, 1 W, 1 kHz)	$\geq -54 \text{ dB}$
Controls		
Bass	(at 500 mV in, 1 W out, 100 Hz)	$\pm 10 \text{ dB} \pm 2 \text{ dB}$
Treble	(at 500 mV in, 1 W out, 10 kHz)	$\pm 10 \text{ dB} \pm 2 \text{ dB}$

DOLBY DIGITAL SECTION

Channel Difference	(FL ref. Track 30)	$\pm 1.2 \text{ dB}$
Frequency Response at Dolby config.2	SL Track 46 200 - 20 kHz	$\pm 0.8 \text{ dB}$
	SR Track 47 200 - 20 kHz	$\pm 0.8 \text{ dB}$
	C Track 44 200 - 20 kHz	$\pm 0.8 \text{ dB}$
Harmonic Distortion (1 W, Audio LPF, Dolby Congfig 1)	FL Track 65 997 Hz	$\leq 0.08 \%$
	FR Track 67 997 Hz	$\leq 0.08 \%$
	SL Track 68 997 Hz	$\leq 0.08 \%$
	SR Track 69 997 Hz	$\leq 0.08 \%$
	C Track 66 997 Hz	$\leq 0.08 \%$
S/N Ratio (31 for O/P 1 W, Track 35)	CCIR / ARM	$\geq 65 \text{ dB}$
	Audio LPF	$\geq 64 \text{ dB}$
	A-wtd	$\geq 68 \text{ dB}$
Channel Separation (1 W, 20 kHz LPF)	Track 65 997 Hz	$\geq 55 \text{ dB}$

DOLBY PRO LOGIC II SECTION

Frequency Response

I/P mode : L, R	: 1 V in, 1 W, Ch L/R	40 Hz	$0 \pm 2.0 \text{ dB}$
		20 Hz	$0 \pm 2.0 \text{ dB}$
I/P mode : L=R	: 1 V in, 1 W, Ch /L/R	40 Hz	$0 \pm 2.0 \text{ dB}$
	Ch C	20 kHz	$0 \pm 2.0 \text{ dB}$
I/P mode : L=-R	: 1 V in, 1 W, Ch SL/SR	40 Hz	$0 \pm 2.0 \text{ dB}$
		20 kHz	$0 \pm 2.0 \text{ dB}$
S/N Ratio (200 mV in, 1 W, A-WTD w/ 1 k termination)			
I/P mode : L, R	: 1 kHz, Ch L/R		$\geq 60 \text{ dB}$
I/P mode : L=R	: 1 kHz, Ch C		$\geq 60 \text{ dB}$
I/P mode : L=-R	: 1 kHz, Ch SL/SR		$\geq 60 \text{ dB}$
THD (2.2 V in, 1 W, w/ 80 kHz LPF, 1 kHz)			$\leq 0.2 \%$

DTS SECTION

Output Level (Vol 0 dB)	: FL/FR/C/SL/SR Track 6	1 kHz	0.5 -0.2/+0.8 W
Channel Difference (FL ref)	: FL/FR/C/SL/SR Track 6	1 kHz	0 ± 1.0 dB
Harmonic Distortion (Audio Filter)	: FL/FR/C/SL/SR Track 10-14	1 kHz	≤ 0.08 %
Frequency Response (20 Hz to 20 kHz)	Track 26-30		+2/-1.5 dB
Subwoofer Output Level	1 kHz ref at pre-out (FL) Play Track 10, charge to 15		12.5 ± 1.5 dB

AM TUNER SECTION

Input level is expressed as the reading in open circuit of 75-ohm source impedance signal generator

Usable sensitivity (999/1000 kHz)		≤ 60 dB_{μV}
S/N Ratio (5 mV in)		≥ 38 dB
THD (5 mV in)		≤ 3 %
IF Rejection (450 kHz)		≤ 36 dB
Image Rejection (F+2xIF)		≥ 28 dB
Selectivity		≥ 17 dB
Output		170 -20/+30 mV
Loop sensitivity (20 dB S/N)		
	999/1000 kHz	≤ 66 dB
	603/600 kHz	≤ 66 dB
	1404/1400 kHz	≤ 66 dB
Frequency Response (100 - 2.3 kHz, 5 mV)		± 6 dB

FM TUNER SECTION

***C**

***AH**

Input level is expressed as the reading in open circuit of 75-ohm source impedance signal generator

Usable sensitivity (98 MHz)		≤ 15 dB_μ	≤ 15 dB_{μV}
S/N Ratio (60 dB, IHF wtd)	Mono	≥ 60 dB	≥ 60 dB
	Stereo	≥ 63 dB	≥ 63 dB
Frequency Response (20 Hz - 15 kHz, 60 dB _μ)		0 ± 1.5 dB	0 ± 1.5 dB
Channel Separation (60 dB _μ)	100 Hz	≥ 30 dB	≥ 30 dB
	1 k	≥ 32 dB	≥ 32 dB
	10 kHz	≥ 30 dB	≥ 30 dB
Alternate Channel Selectivity (40 dB _μ , ± 400 kHz)		≥ 60 dB	≥ 45 dB
Capture Ratio (40 dB _μ)		≤ 3 dB	≤ 3 dB
AM Suppression (60 dB _μ , 100% Mod. FM, 30% Mod. AM)		≥ 48 dB	≥ 48 dB
Image Rejection (119.4 MHz)		–	≥ 65 dB
I.F. Rejection (10.7 MHz)		≥ 78 dB	–
Pilot Suppression (98 MHz)		≥ 50 dB	≥ 50 dB
THD (60 dB _μ , L=R 75 kHz for AH, 40 kHz Dev for C)	Mono	≤ 0.5 %	≤ 0.5 %
	Stereo	≤ 0.5 %	≤ 0.5 %
Auto-Search Sensitivity	On	≥ 24 dB_μ	≥ 24 dB_μ
	Off	≤ 15 dB_μ	≤ 15 dB_μ
RDS decode Sensitivity		≤ 26 dB_μ	–

PHYSICAL SPECIFICATIONS

Dimensions (Width x Height x Depth)	435 x 160 x 393 mm
Net Weight	17.9 Kg (39.38 lbs)
Shipping Weight	22.7 Kg (49.94 lbs)

REAR PANEL / FRONT PANEL VIEW

REAR PANEL

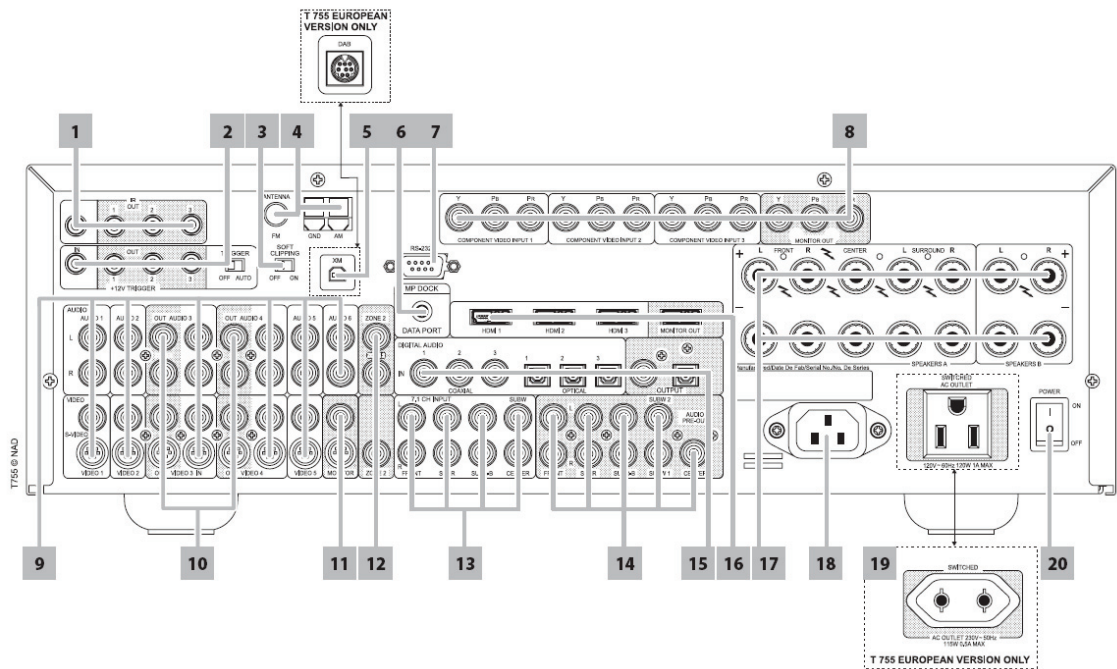

- | | | |
|--|-----------------------------|---------------------------|
| 1. IR IN/OUT | 7. RS-232 | 13. 7.1 CH INPUT |
| 2. +12V TRIGGER OUT | 8. COMPONENT IN/OUT | 14. AUDIO PREOUT |
| 3. SOFT CLIPPING | 9. AUDIO/VIDEO 1~6 IN | 15. DIGITAL AUDIO IN/OUT |
| 4. FM,AM ANTENNA INPUT | 10. AUDIO/VIDEO 3/4 OUT | 16. HDMI |
| 5. XM MODULE INPUT(AH)
DAB MODULE INOUT(C,CT) | 11. MONITOR(S-VIDEO, VIDEO) | 17. SPEAKERS A, SPEAKER B |
| 6. MP DOCK | 12. ZONE 2 | 18. AC POWER INLET |
| | | 19. SWITCHED AC OUTLET |
| | | 20. POWER |

FRONT PANEL

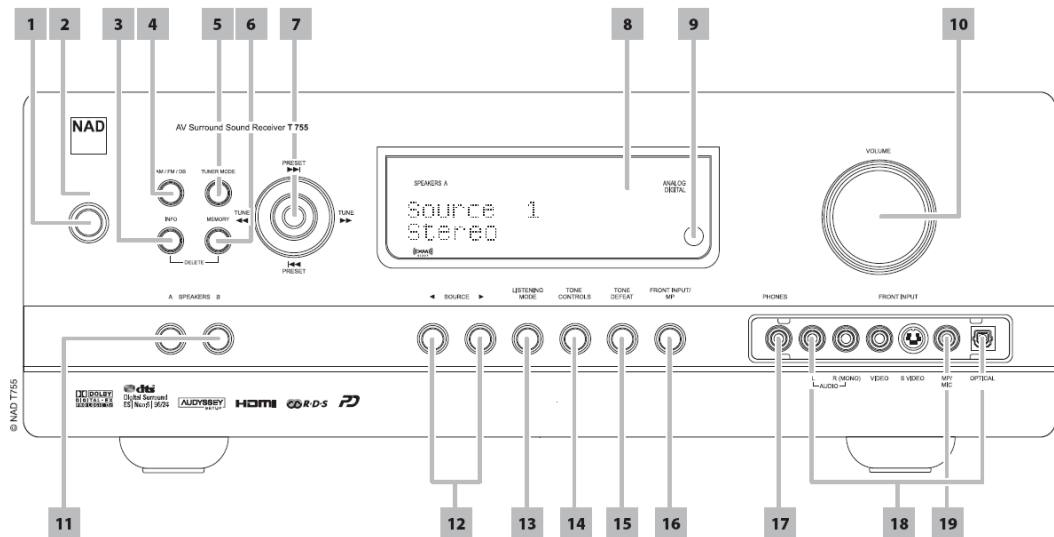

- | | | |
|-----------------------------------|---------------------------------------|-----------------------|
| 1. POWER BUTTON | 8. VACUUM FLUORESCENT
DISPLAY(VFD) | 14. TONE CONTROLS |
| 2. STANDBY LED | 9. REMOTE SENSOR | 15. TONE DEFEAT |
| 3. INFO | 10. VOLUME | 16. FRONT INPUT/MP |
| 4. AM/FM/DB | 11. SPEAKERS A, B | 17. PHONES |
| 5. TUNER MODE | 12. SOURCE | 18. FRONT INPUT JACKS |
| 6. MEMORY | 13. LISTENING MODE | 19. MC/MIC INPUTS |
| 7. NAVIGATION AND
ENTER BUTTON | | |

DISASSEMBLY INSTRUCTIONS

1. Remove machine screws M4.0 x 8.0 (**x 6pcs**) from the side panels.
Remove tapping screw 3.0 x 8.0 (**x 4pcs**) from the back panel.
Refer to **Figure No. 1**.

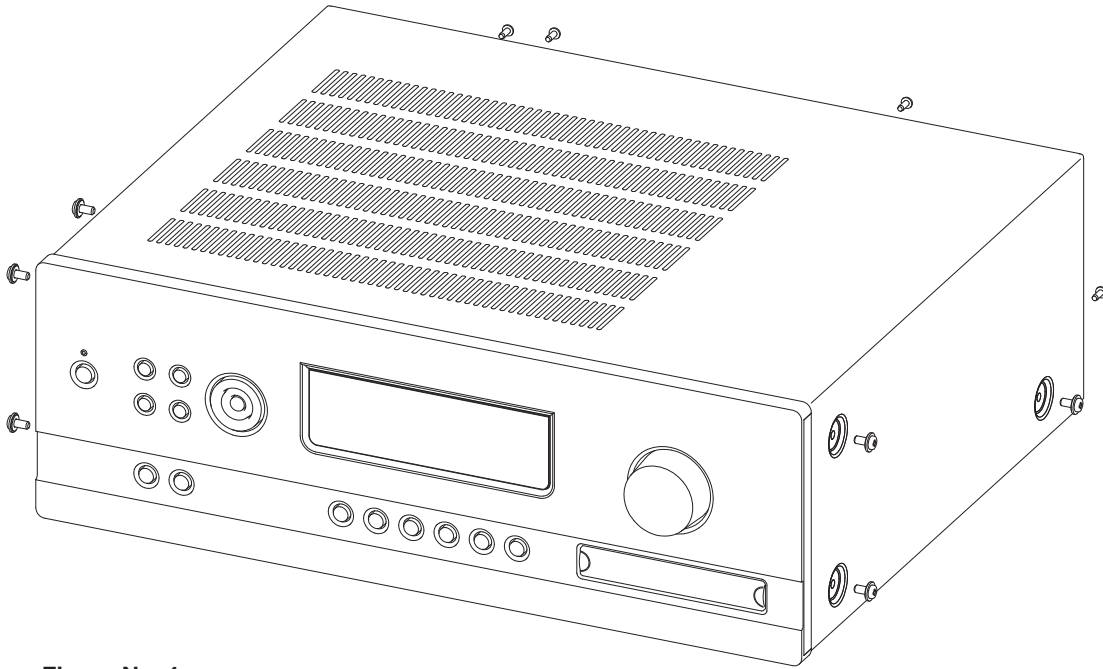

Figure No. 1

2. Pull both sides of the TOP COVER slightly outwards and tilt approx. 35 ° and then remove in the direction as indicated. Refer to **Figure No. 2**.

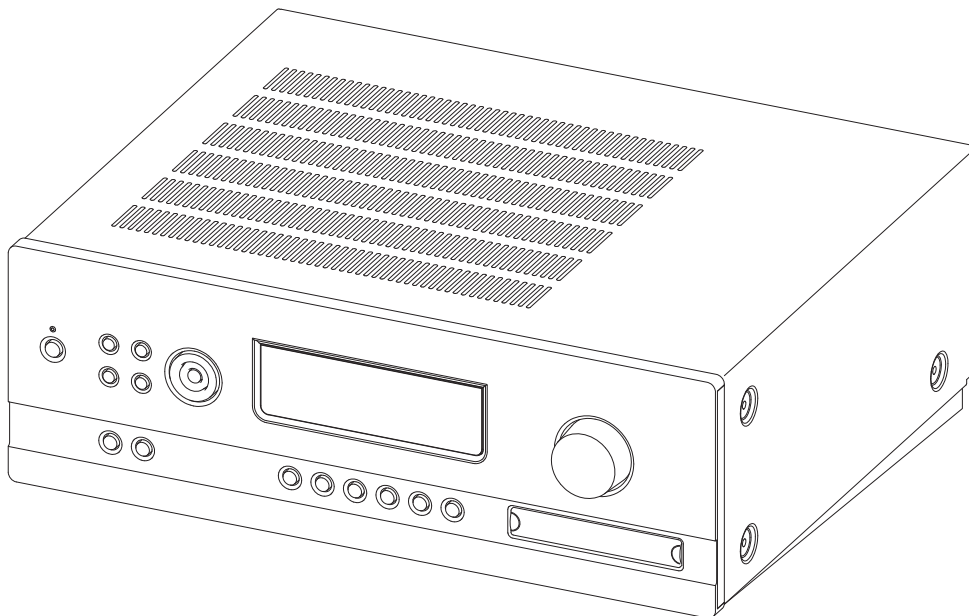
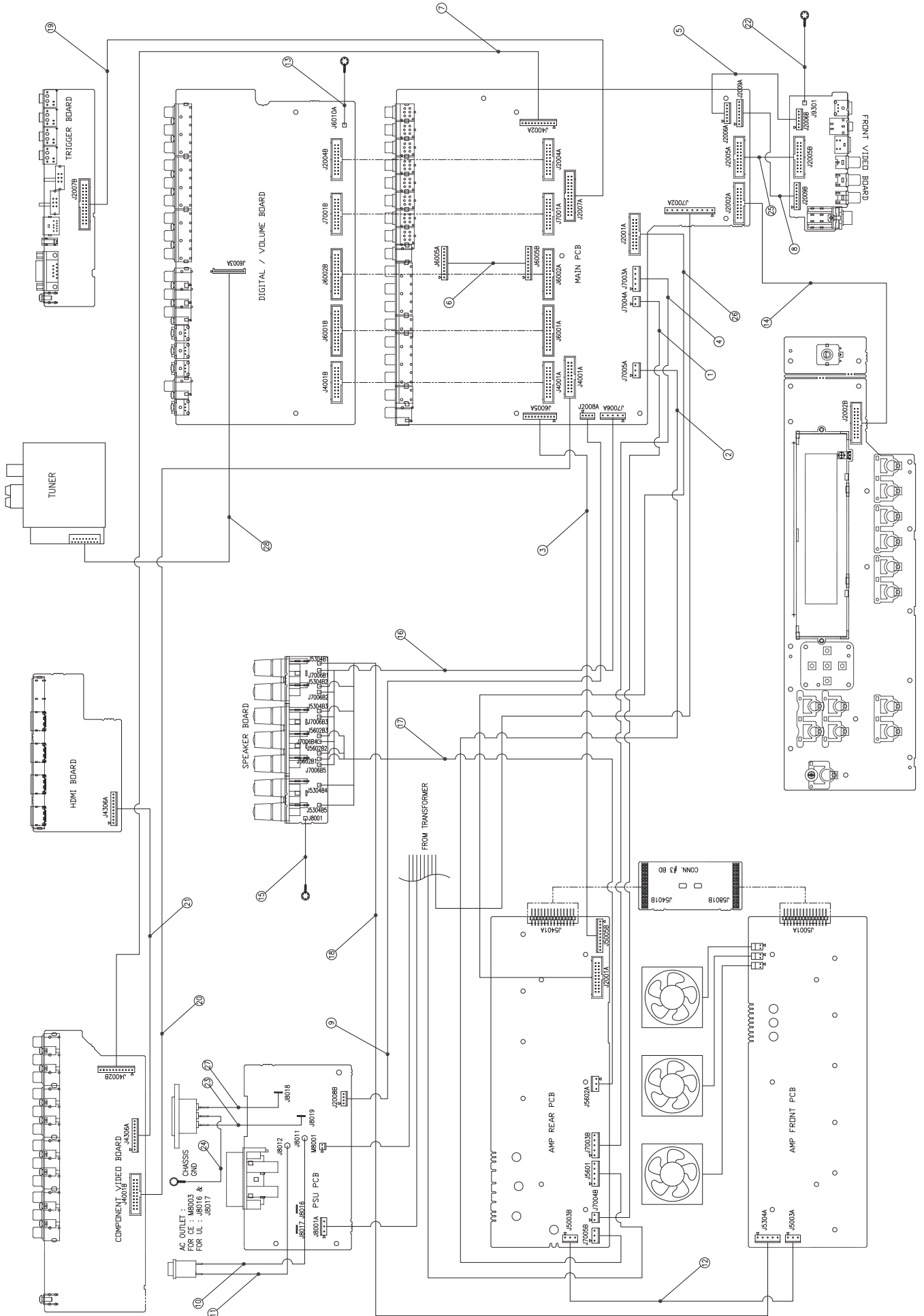

Figure No. 2

WIRING DIAGRAM



WIRING DIAGRAM PARTS LIST

Item	Database Part Number	Description	Remark
1	17-012-3379-90	CABLE ASSY 2 WAYS AWG18 3.96P UL1007 L=250mm(RoHS)	MAIN BD- J7004A
2	17-012-3380-90	CABLE ASSY 3 WAYS AWG18 3.96P UL1007 L=250mm(RoHS)	MAIN BD- J7005A
3	17-012-3382-90	CABLE ASSY 10 WAYS AWG26 2.5P UL1533 L=300mm(RoHS)	MAIN BD- J6005A
4	17-012-3575-90	CABLE ASSY 5 WAYS AWG18 3.96P UL1007 L=230mm (RoHS)	MAIN BD- J7003A
5	17-012-3579-90	CABLE ASSY 6 WAYS AWG26 2.5P UL1533 L=80mm (RoHS)	MAIN BD- J2006A
6	17-012-3974-90	CABLE ASSY 10WAYS AWG#26 2.5P UL1007 L=110mm BOTH SIDE SOLDER (RoHS)	MAIN BD- J6010A/B
7	17-012-4274-90	CABLE ASSY 12 WAYS AWG26 2.5P UL1533 2.5P L=350mm (RoHS)	MAIN BD- J4002A
8	17-012-4275-90	CABLE ASSY 8 WAYS AWG26 UL1533 2.5P L=140mm (RoHS)	MAIN BD- J2009A
9	17-012-3571-90	CABLE ASSY 4 WAYS AWG26 2.5P L=120mm (RoHS)	PSU BD- J2008B
10	17-012-3943-90	CABLE ASSY 1 WAY AWG16 UL1672 BLUE L=140mm FASTON 4.8mm (RoHS)	PSU BD- J8011
11	17-012-3944-90	CABLE ASSY 1 WAY AWG16 UL1672 BROWN L=140mm FASTON 4.8mm (RoHS)	PSU BD- J8012
12	17-012-3578-90	CABLE ASSY 3 WAYS AWG18 3.96P UL1007 L=120mm (RoHS)	SURR AMP BD- J5003B
13	17-012-2956-90	CABLE ASSY 1 WAY AWG18 UL1007 BLACK L=100mm W/ RING TERMINAL	DSP BD- J6010A
14	17-012-3971-90	CABLE ASSY 20 WAYS AWG28 UL2651 L=120mm PCB MOUNT (RoHS)	KEY BD- J2002B
15	17-012-2956-90	CABLE ASSY 1 WAY AWG18 UL1007 BLACK L=100mm W/ RING TERMINAL	SPK BD- J8001
16	17-012-3383-90	CABLE ASSY 5 WAYS AWG=18 3.96P UL1007 L=350mm(V/B/Y/O/R)(RoHS)	SPK BD- J7006
17	17-012-3576-90	CABLE ASSY 3 WAYS AWG18 3.96P UL1007 L=420mm (RoHS)	SPK BD- J5602
18	17-012-3577-90	CABLE ASSY 5 WAYS AWG18 3.96P UL1007 L=340/380/400mm (RoHS)	SPK BD- J5304
19	17-012-3385-90	CABLE ASSY 26 WAYS AWG28 UL2651 L=150mm PCB MOUNT(RoHS)	TRIGGER BD- J2007B
20	17-012-4276-90	CABLE ASSY 20 WAYS AWG28 UL2651 L=200mm PCB MOUNT (RoHS)	COMP.VID. BD- J4001B
21	17-012-3168-90	CABLE ASSY 10 WAYS AWG26 UL1007 2.5P L=160mm (RoHS)	HDMI BD- J4306A
22	17-012-2956-90	CABLE ASSY 1 WAY AWG18 UL1007 BLACK L=100mm W/ RING TERMINAL	FRONT INPUT BD-J9301
23	17-012-2874-90	Cable assy 1 way AWG=16 UL 1672 blue L=100mm (RoHS)	J8017,J8019
24	17-012-2875-90	CABLE ASSY 1 WAY AWG16 UL 1015 GREEN/YELLOW L=100mm (RoHS)	CHASSIS GND, AC OUTLET GND
25	17-012-3572-90	CABLE ASSY 20 WAYS AWG28 UL2651 L=80mm (RoHS)	J2005C
26	17-012-3573-90	CABLE ASSY 20 WAYS AWG28 UL2651 L=130mm (RoHS)	J2001C
27	17-012-3948-90	CABLE ASSY 1 WAY AWG16 UL1672 BROWN L=100mm (RoHS)	J8016,J8018
28	17-010-0165-90	FFC CABLE 17 PINS P1.25 L=80MM (RoHS)	J6003C

BLOCK DIAGRAM

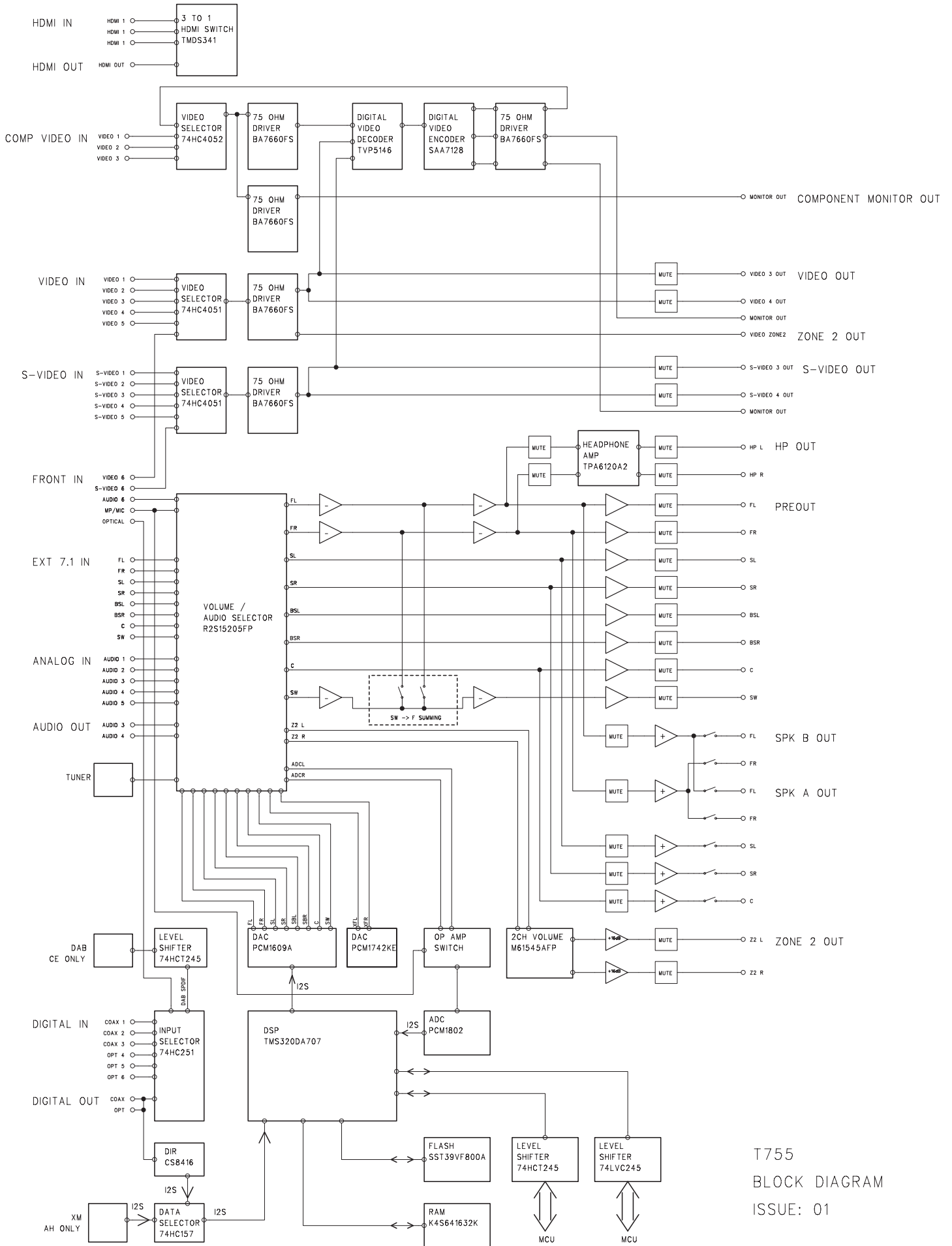

T755
BLOCK DIAGRAM
ISSUE: 01

SPECIAL FUNCTION

Function	Keys	Notes
Factory Reset AH	Source Down + Front/MP	
Factory Reset C	Source UP + Front/MP	
Toggle IR Channel	Source Down + Power	
Check MCU & DSP Version	Source Down + Source UP	
Check Current Video Mode	Source Down + Tone Controls	
MIC Test	Source Down + Tone Defeat	
VFD Test	Source Down + INFO	
PAL/NTSC	Source Down + Memory	
DAB/XM	Source Down + Tuner Band	Must cycle power before change takes effect.
9k/10k	Source UP + Tuner Band	Must reselect AM before change takes effect.
XM 1kHz Test Tone	Tuner Band + Tuner Mode	XM must be selected first.
XM Signal Strength	Tuner Mode for 0.5 seconds	XM must be selected first.
XM Diagnostics Mode	Tuner Mode for 3 seconds	XM must be selected first.
Check DAB Module Version	Tuner Mode for 3 seconds	DAB must be selected first.
Enter Diagnostics Mode	Source Down + Enter	
Diagnostic Mode Down	Source Down + Cursor Right	
Diagnostic Mode Up	Source Down + Cursor Left	
Power Off All Zones	Power Toggle or Power Off for 3 seconds	

DETAILS & WAVEFORMS ON SYSTEM TEST & DEBUGGING

U1001 Pin 17 - X1001C output, 24.576MHz

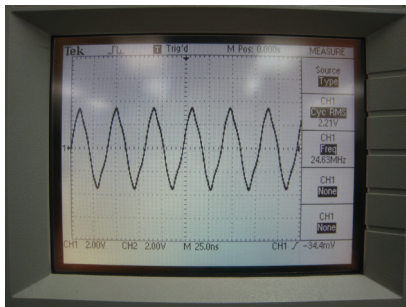

U1001 Pin 70 - Clock for external memory, 100MHz

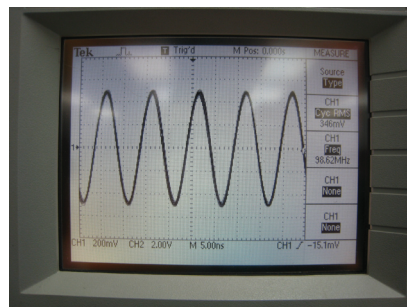

U1001 Pin 2 - Master clock (Analog), 12.288MHz

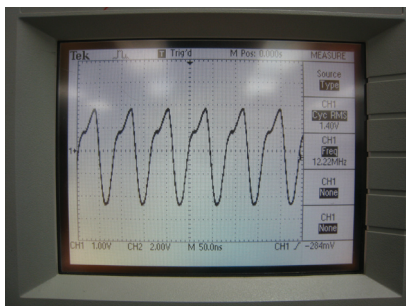

U1001 Pin 2 - Master clock (PCM), 11.2896MHz

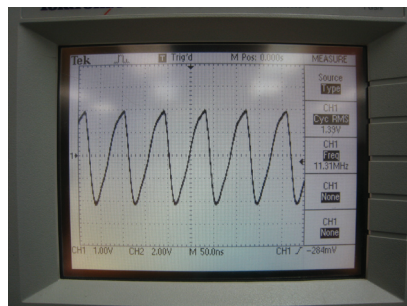

U1001 Pin 12 - Left/Right clock (Analog), 48kHz

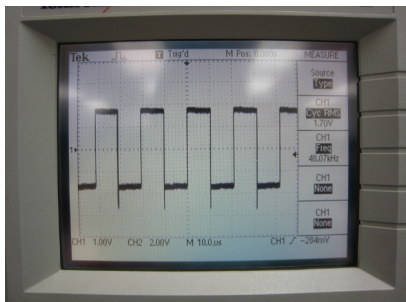

U1001 Pin 12 - Left/Right clock (PCM), 44.1kHz



U1001 Pin 9 - Serial clock (Analog), 3.072MHz

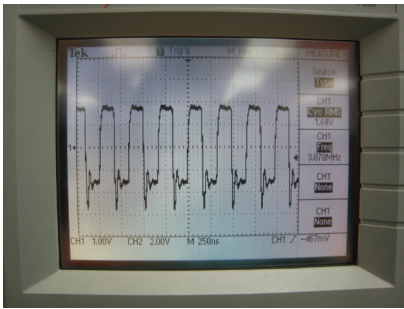

U1001 Pin 9 - Serial clock (PCM), 2.8224MHz

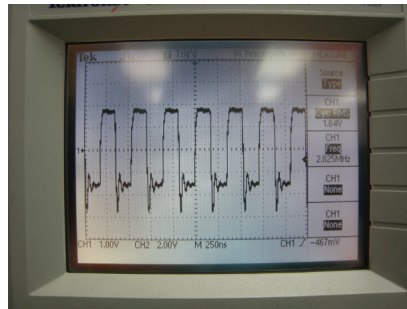

U2001 Pin 12 - X2001A output, 20.000MHz

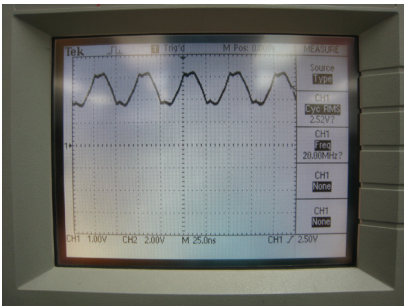

U4520 Pin 7 - X4503 output, 13.500MHz

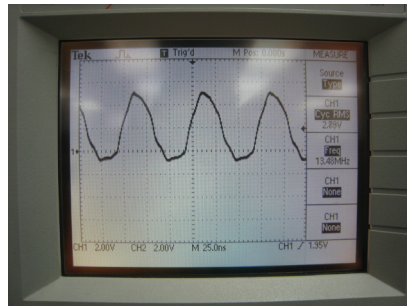

U4507 Pin 75 - X4501 output, 14.31818MHz

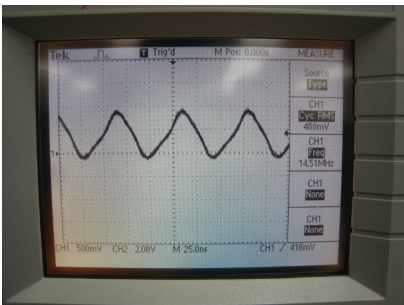

ADJUSTMENT POINT DIAGRAM

LEFT/RIGHT CHANNEL AMPLIFIER BOARD

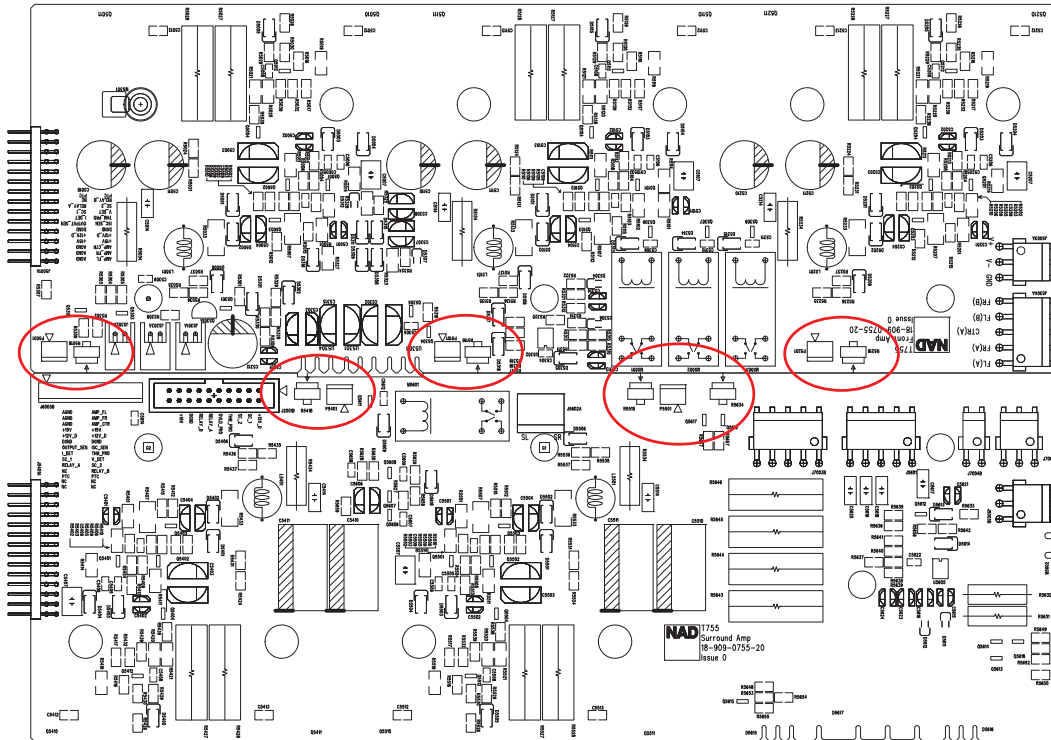

AMPLIFIER ADJUSTMENT

Idle Current

1. Rotate R5018 fully anti-clockwise.
2. Connect DC millivoltmeter to P5001.
3. Turn on the unit.
4. Adjust R5018 for 2mV +/- 0.2mV reading on voltmeter.
5. Leave power on for at least 5 min, and check for idle current again.
6. Repeat for other channels.

CHANNEL	JUMPER	VR
FL	P5001	R5018
FR	P5101	R5118
C	P5201	R5218
SL	P5401	R5418
SR	P5501	R5518

ISC Adjustment

- A. Rotate R5634 fully clockwise.
- B. Use 500mV, 1kHz sine wave, EXT7.1 input, 8ohm loading to all channels.
- C. Increase the output power of each channels to 80W(25.3V).
- D. Note the THD readings should be larger than 0.2%.
- E. Rotate R5624 anti-clockwise slowly until the THD readings is below 0.1%.

PCB LAYOUT POWER AMPLIFIER FRONT AMP BOARD-COPPER SIDE

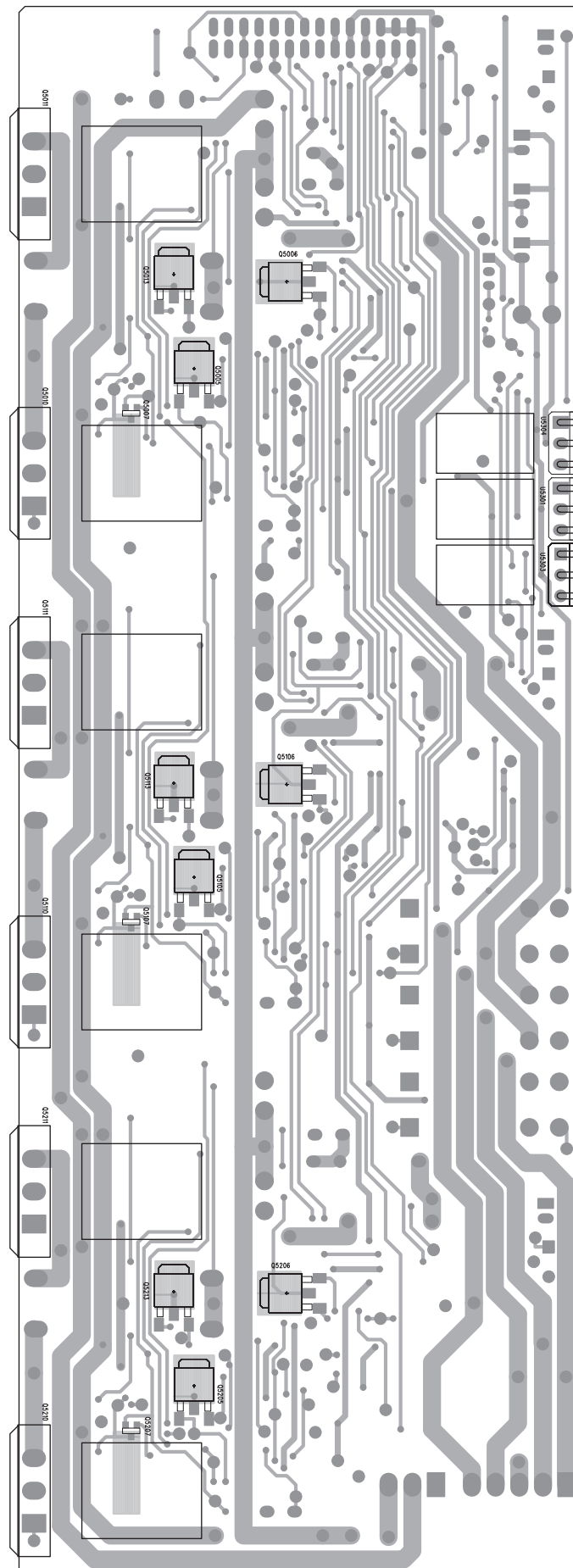

FRONT AMP BOARD-COMPONENT SIDE

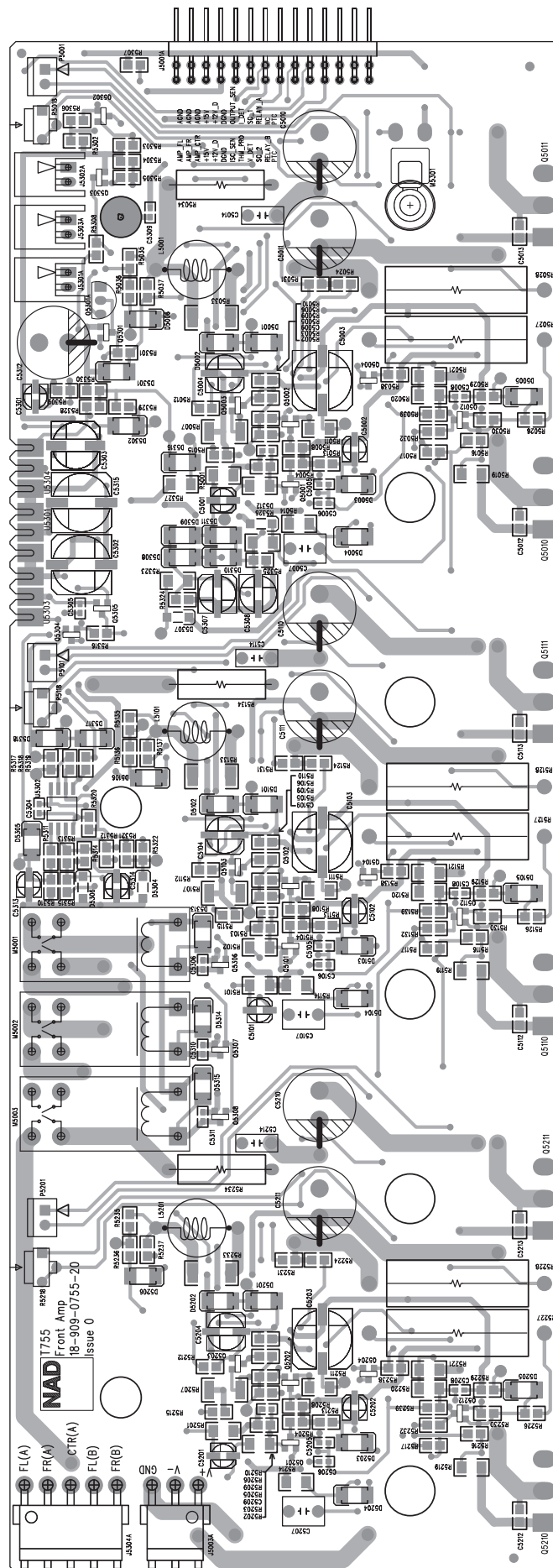

SURROUND AMP BOARD-COPPER SIDE

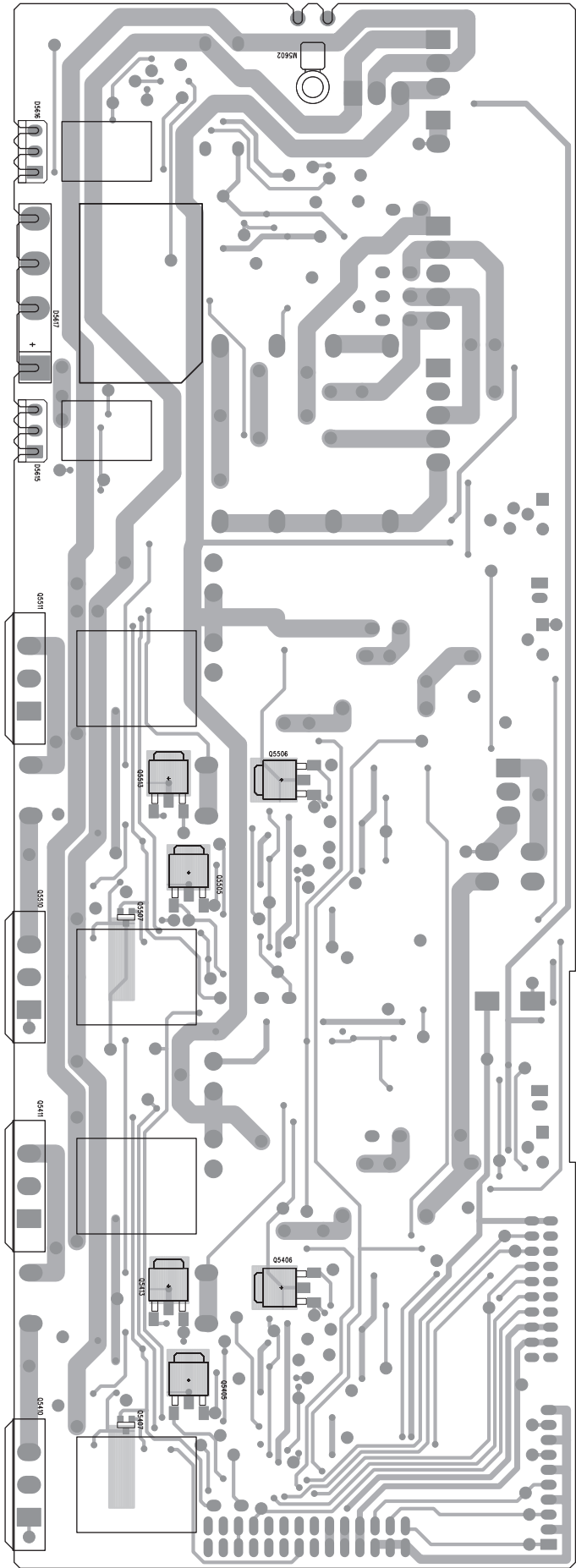

DSP BOARD - COPPER SIDE

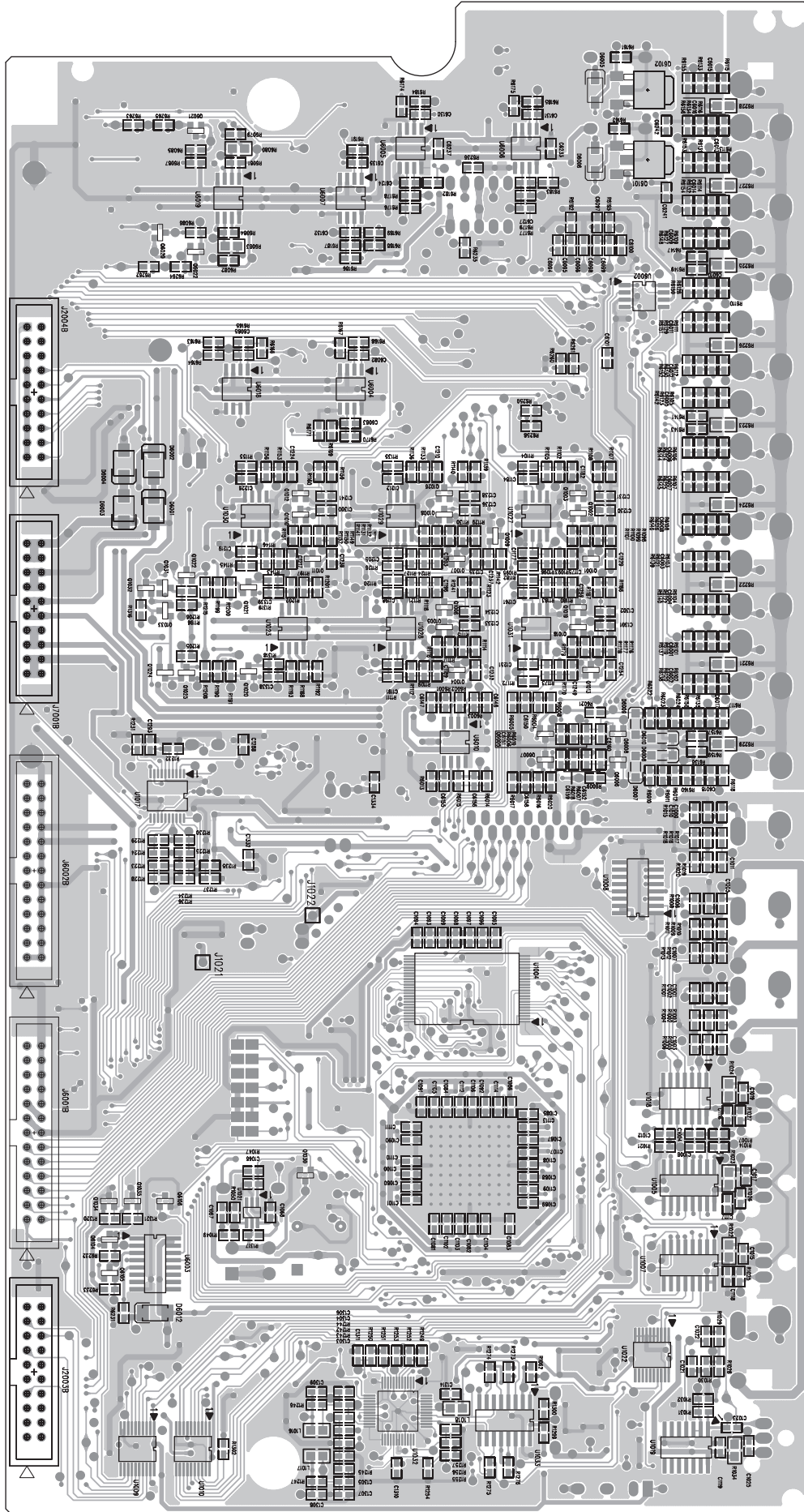

DSP BOARD - COMPONENT SIDE

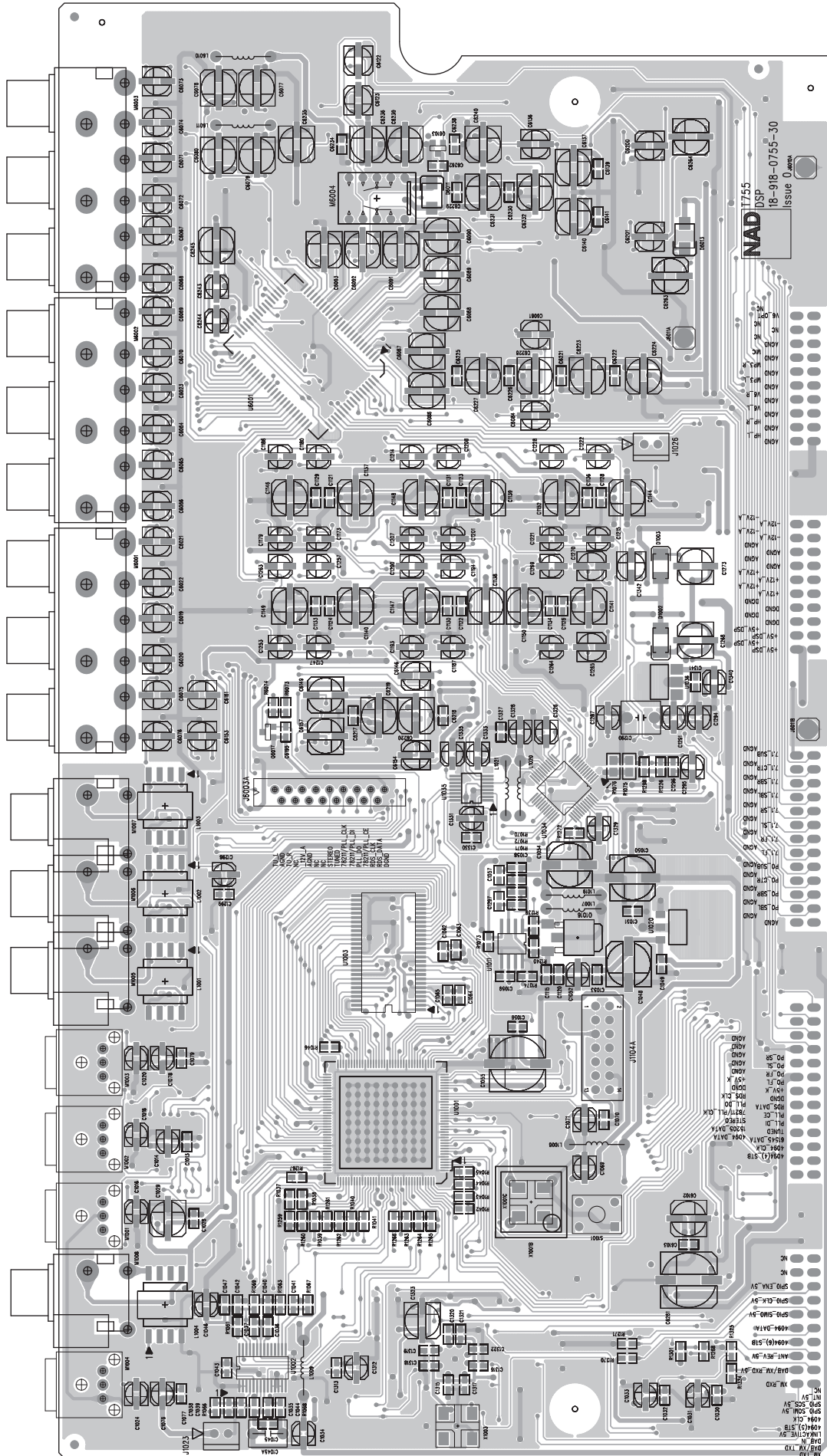

F-VIDEO BOARD - COPPER SIDE

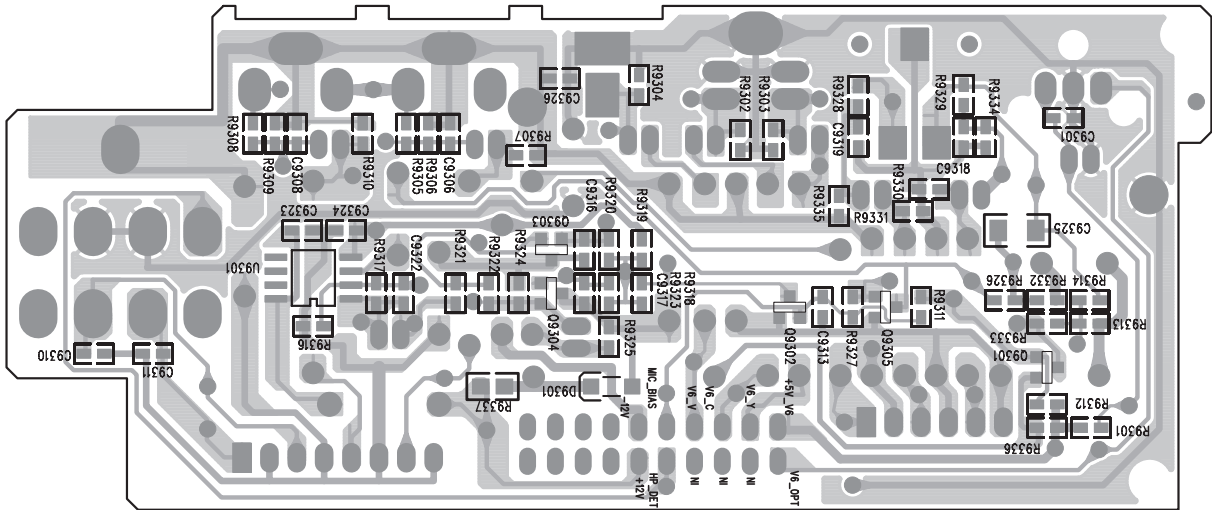

F-VIDEO BOARD - COMPONENT SIDE

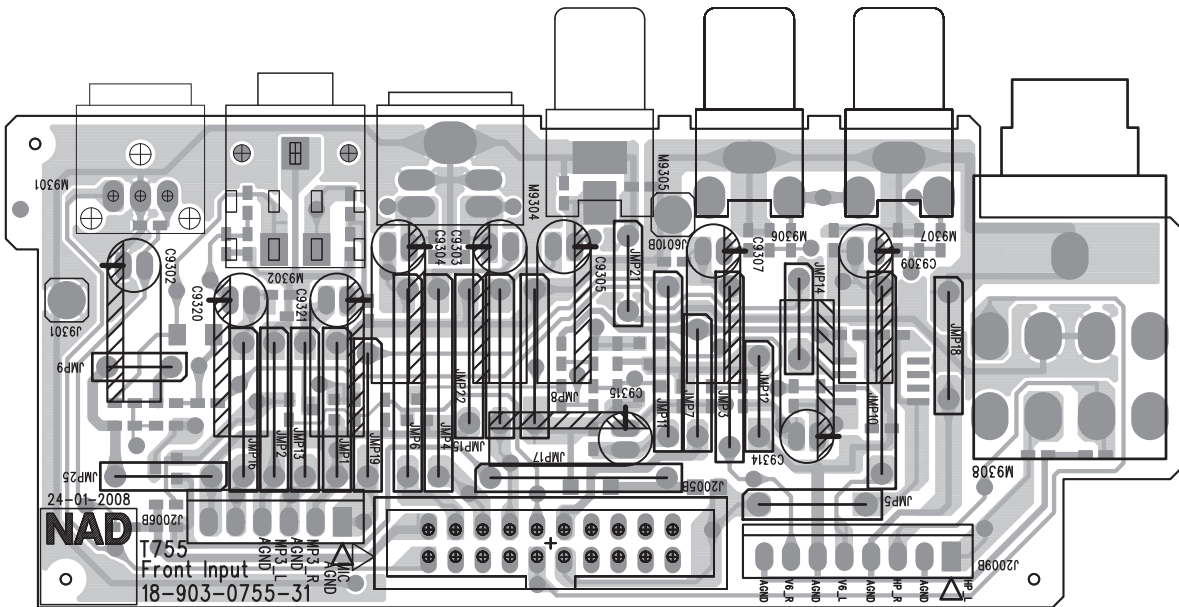

MAIN BOARD -COMPONENT SIDE

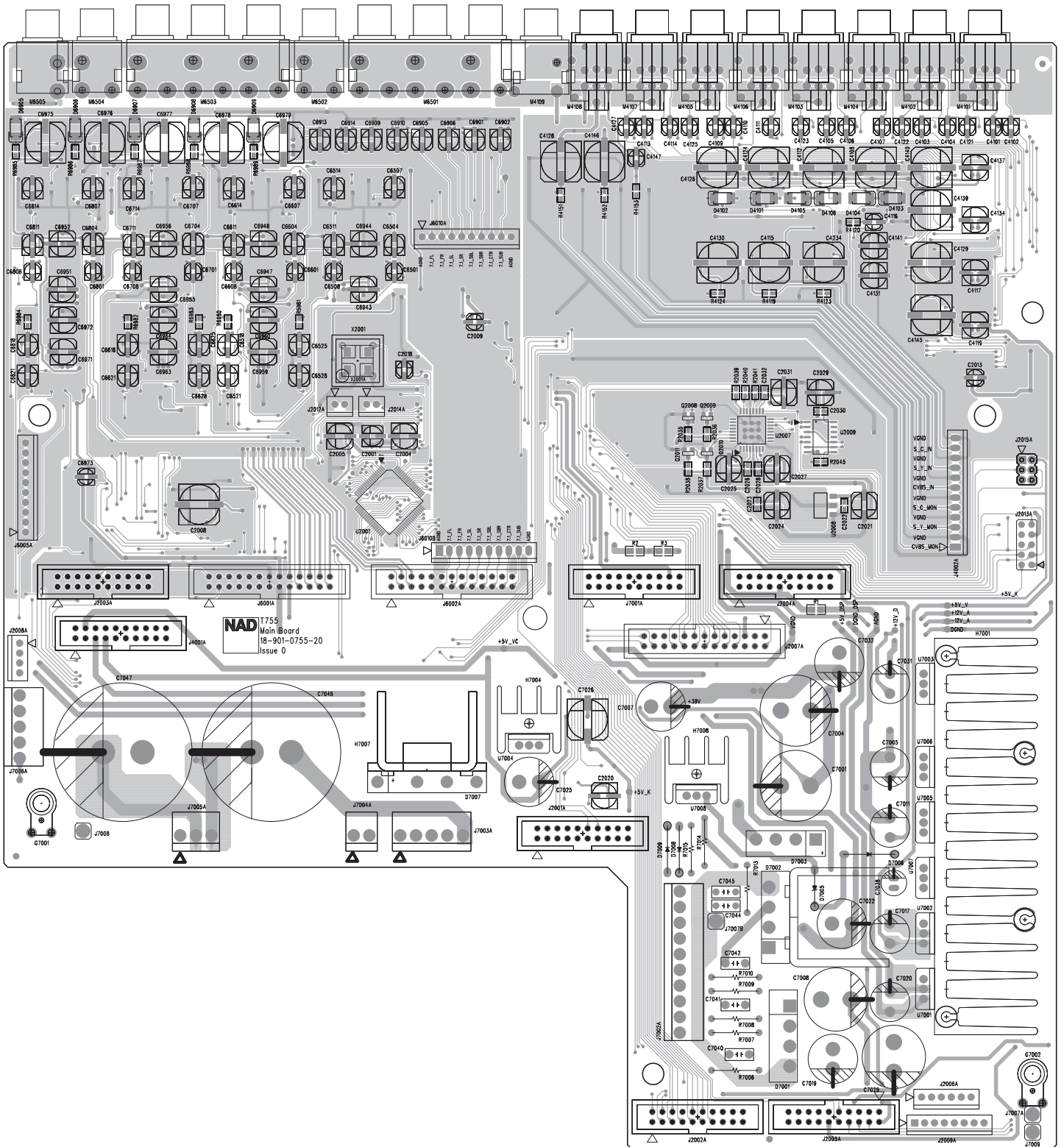

MAIN BOARD -COPPER SIDE

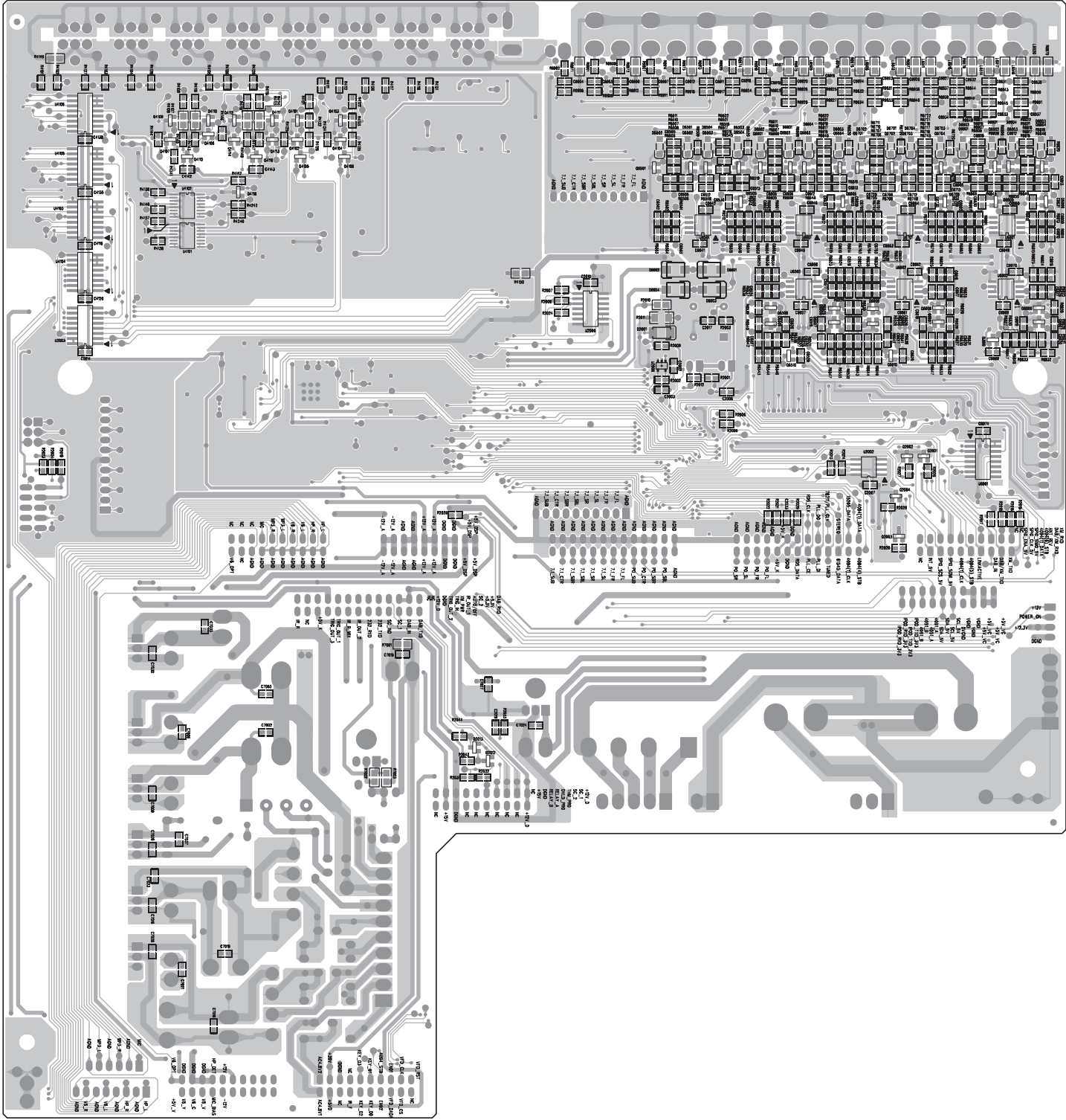

TRIGGER BOARD - COMPONENT SIDE

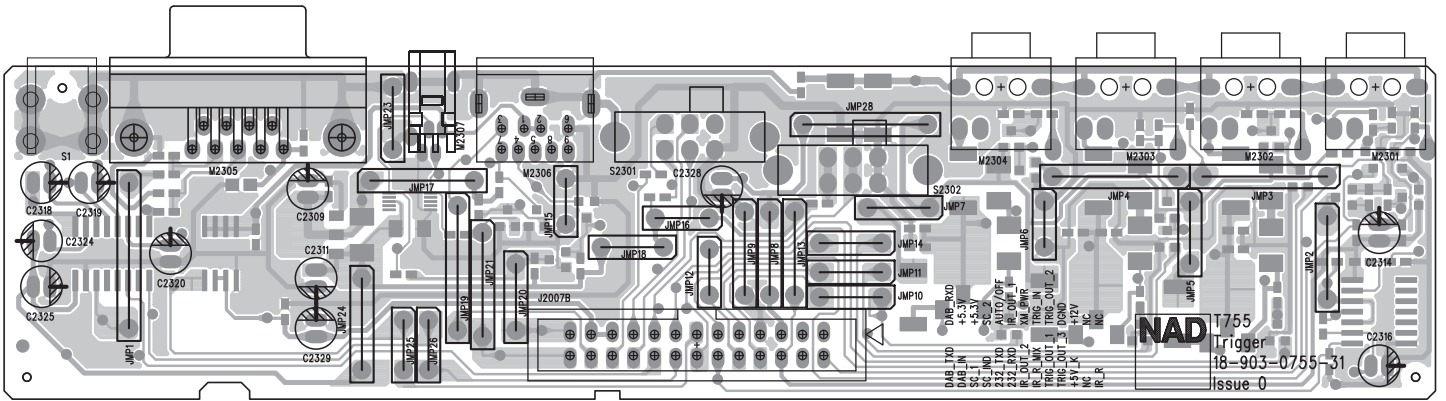

TRIGGER BOARD - COPPER SIDE

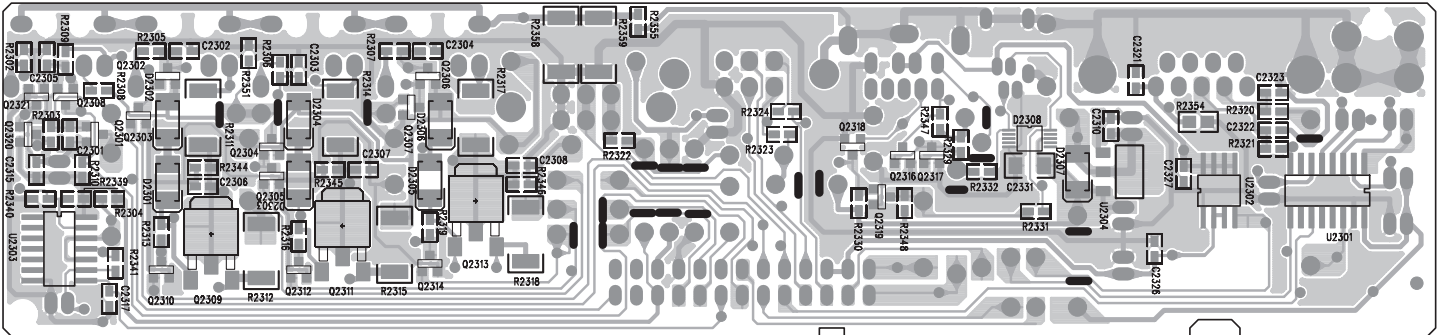

SPEAKER BOARD - COMPONENT SIDE

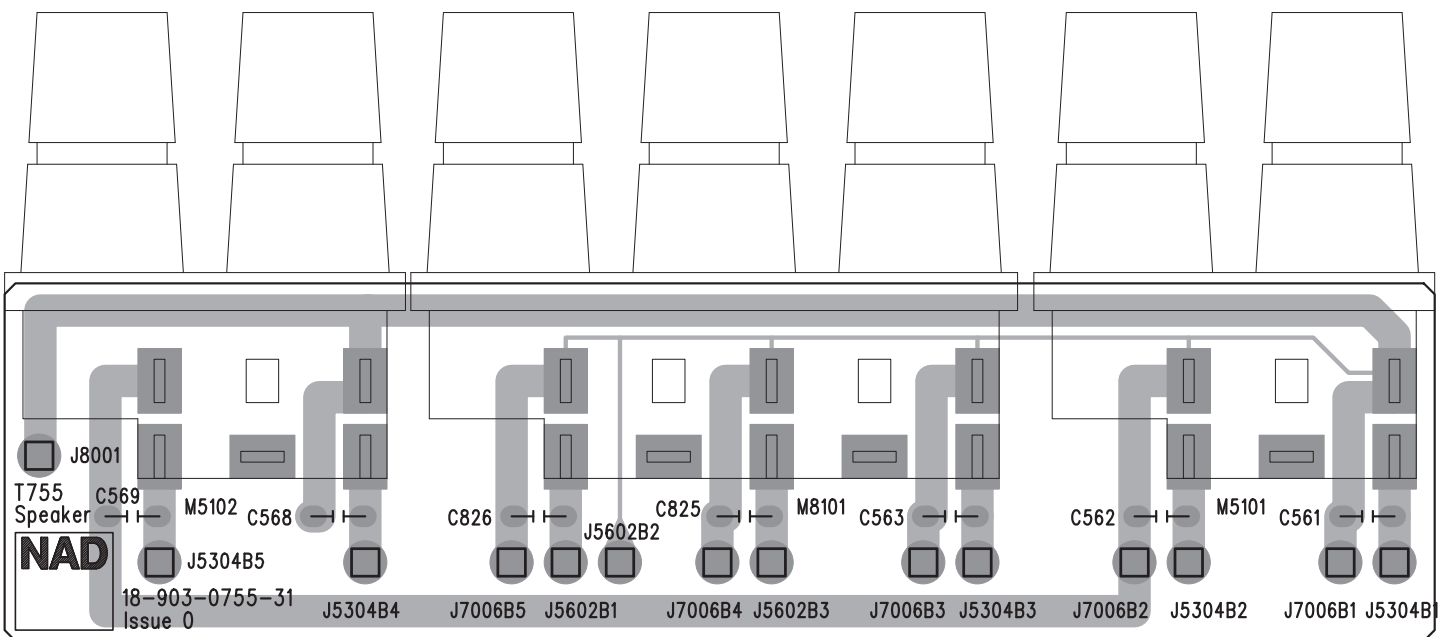

COMPONENT BOARD-COMPONENT SIDE

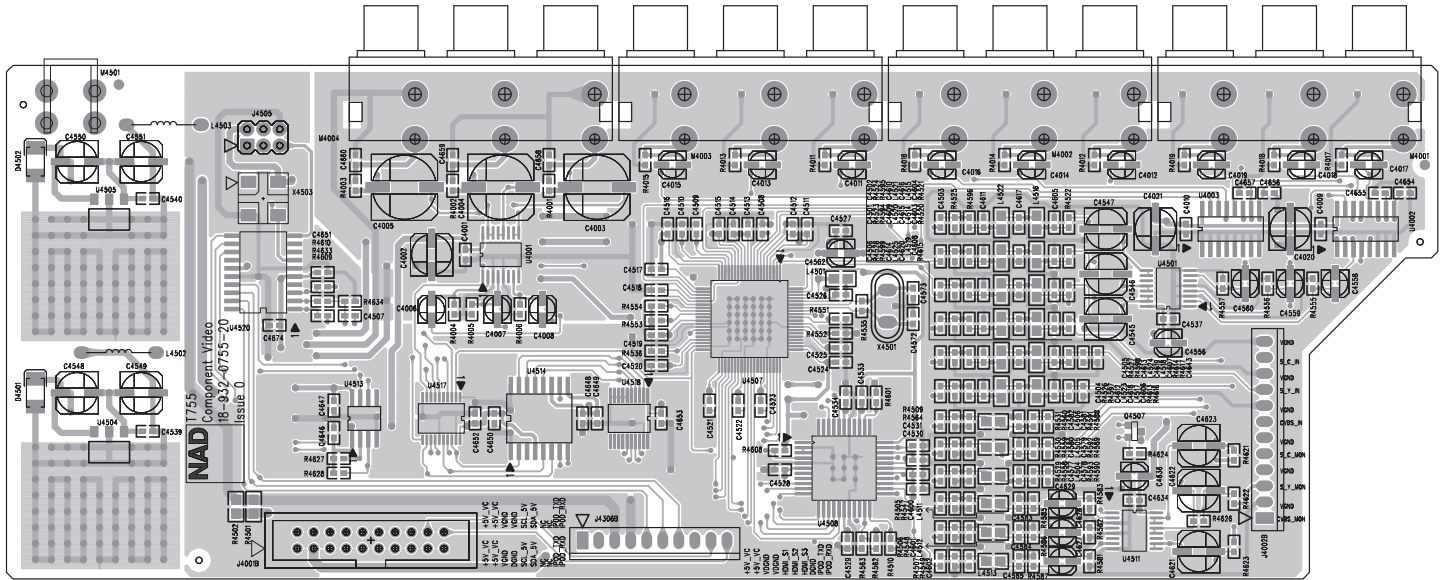

COMPONENT BOARD-COPPER SIDE

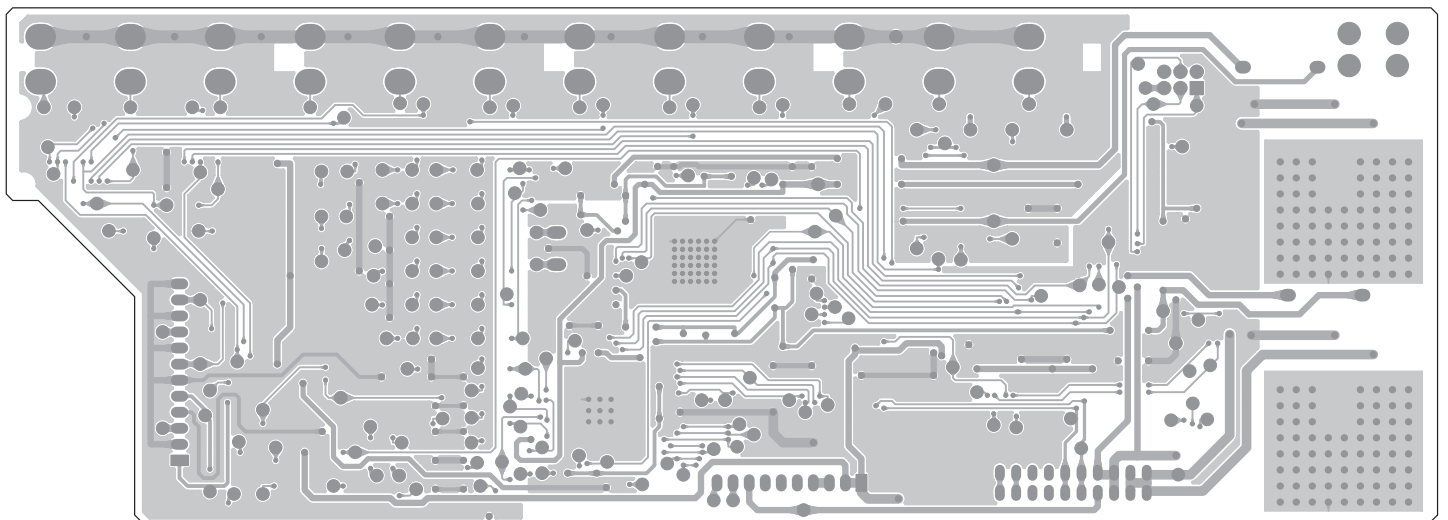

HDMI BOARD-COPPER SIDE

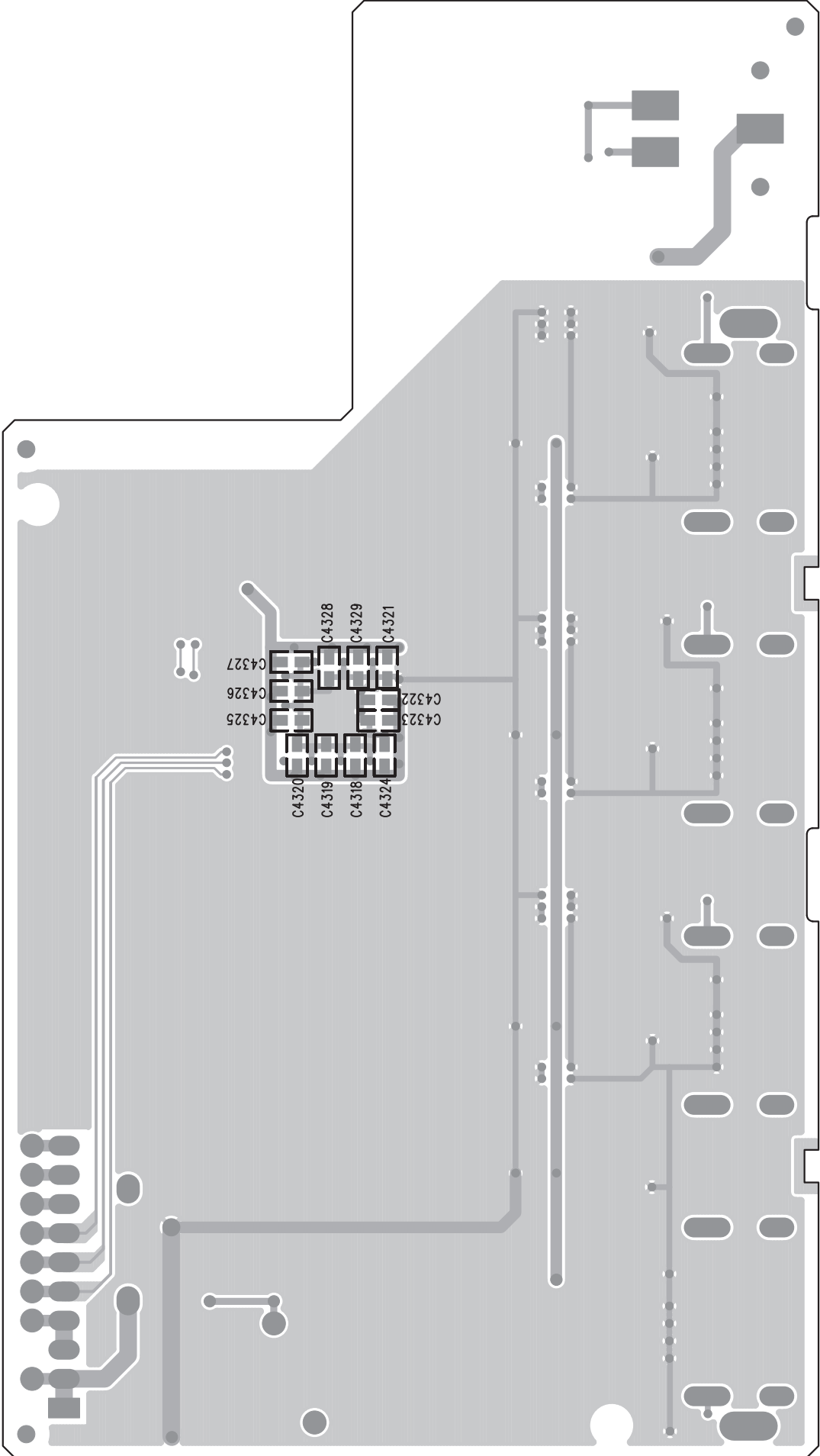

HDMI BOARD-COMPONENT SIDE

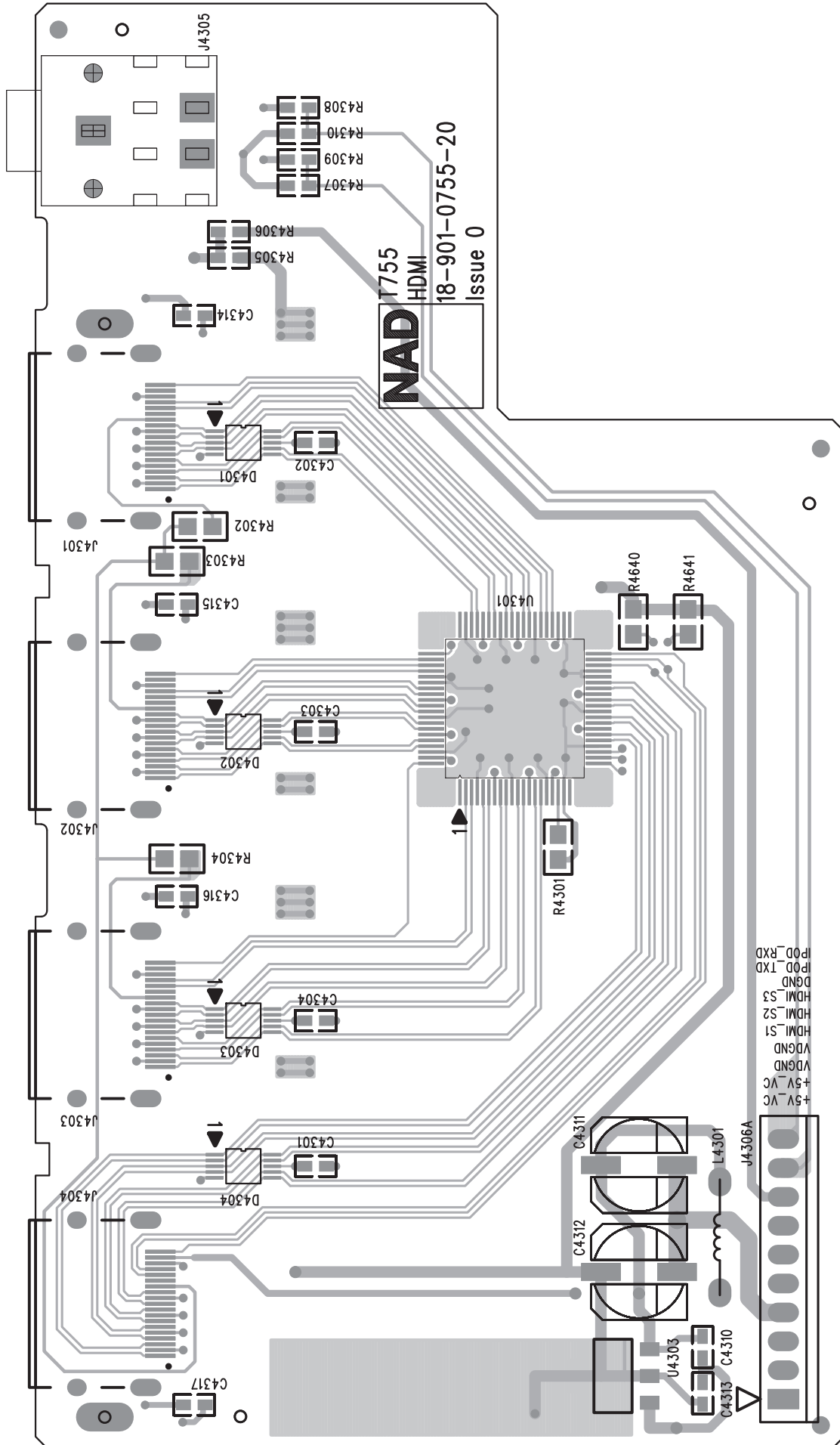

PSU-STD BOARD-COMPONENT SIDE

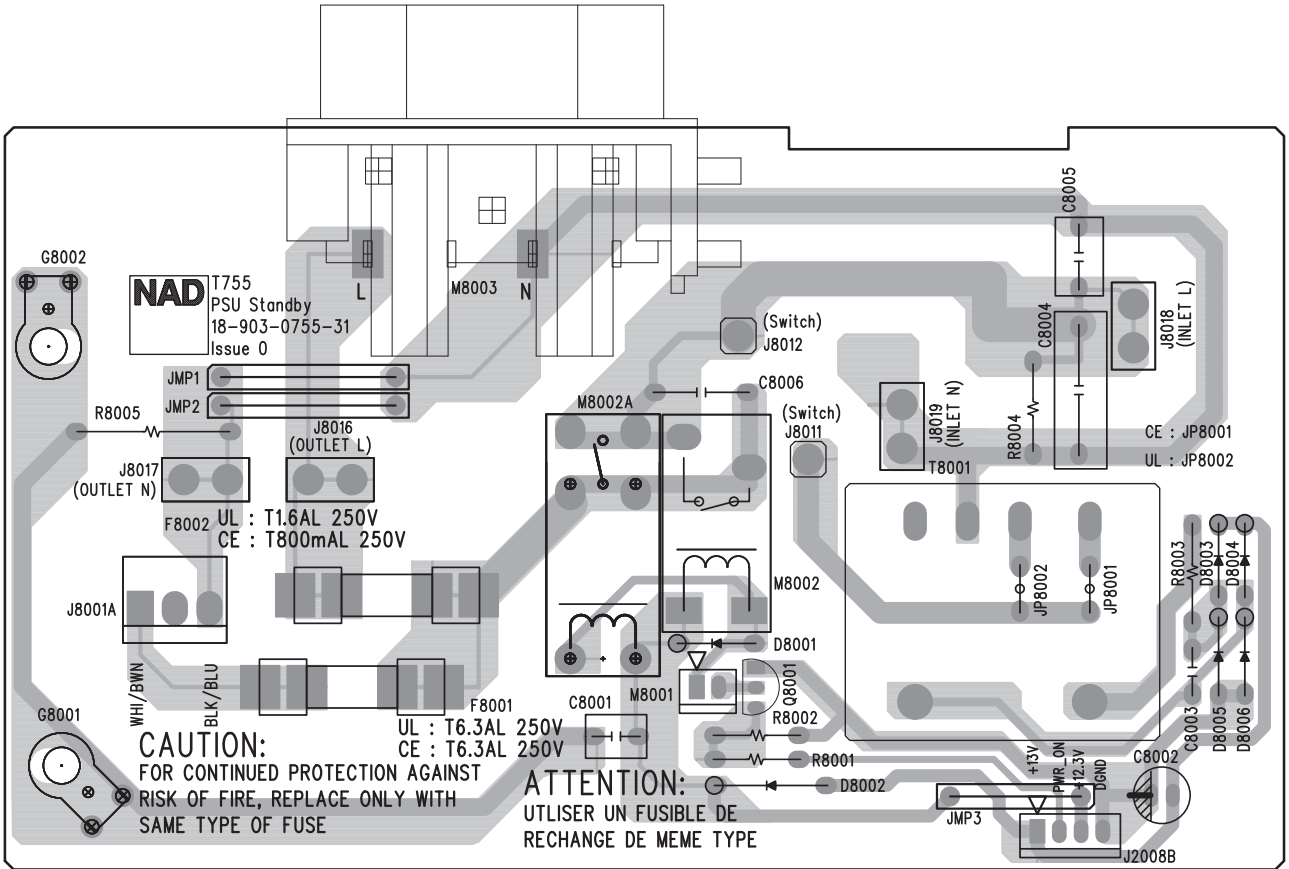

CONNECTOR-3 BOARD-COMPONENT SIDE

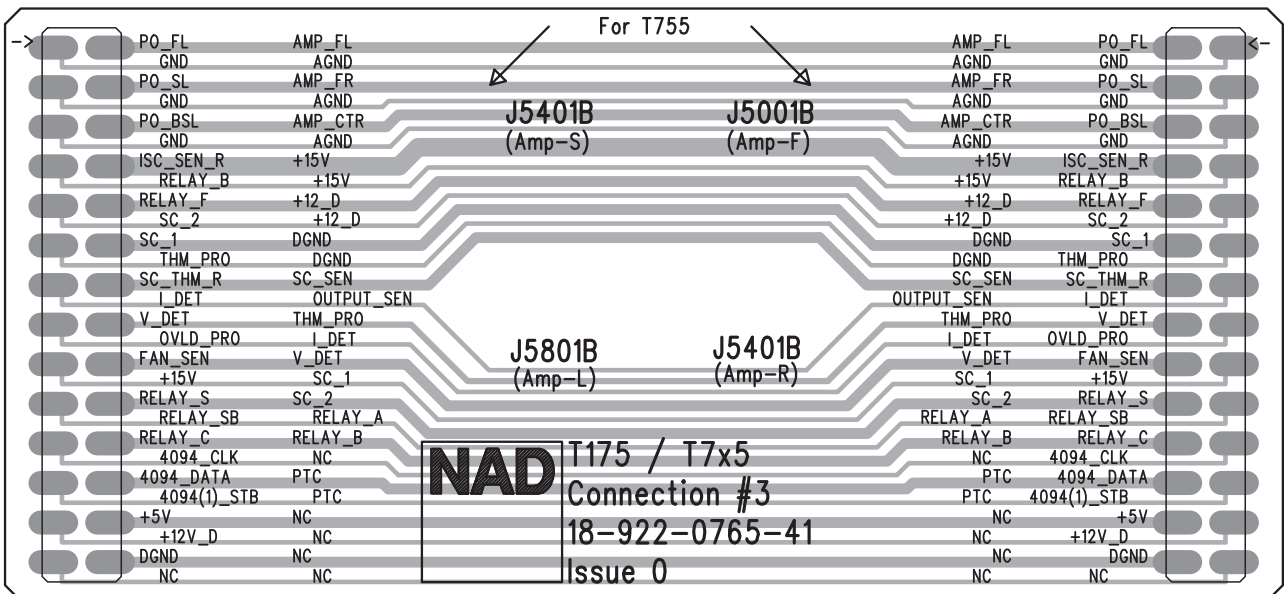

SCHEMATIC DAIGRAM CONNECTOR-3

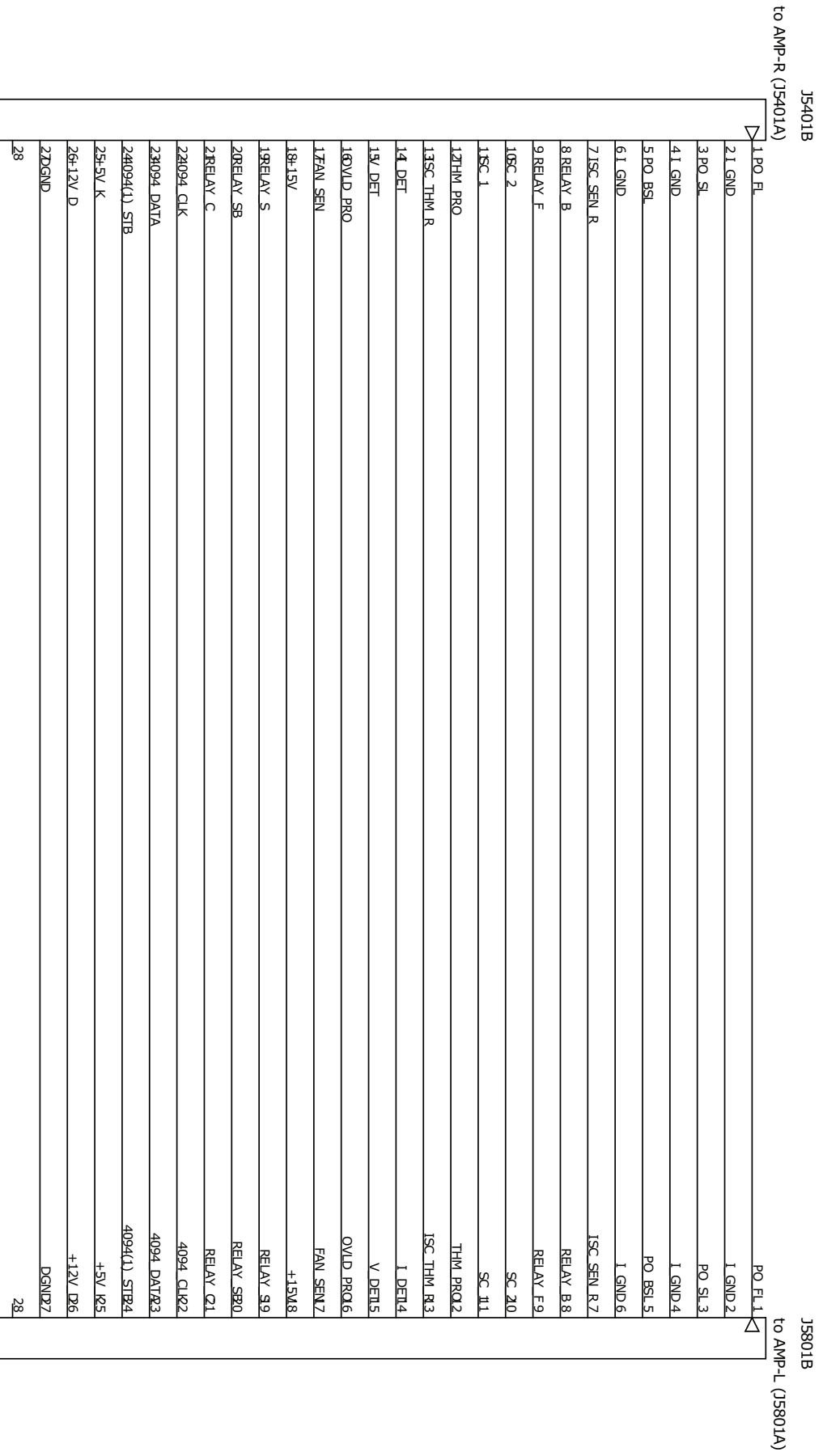

POWER SUPPLY(STAND BY)

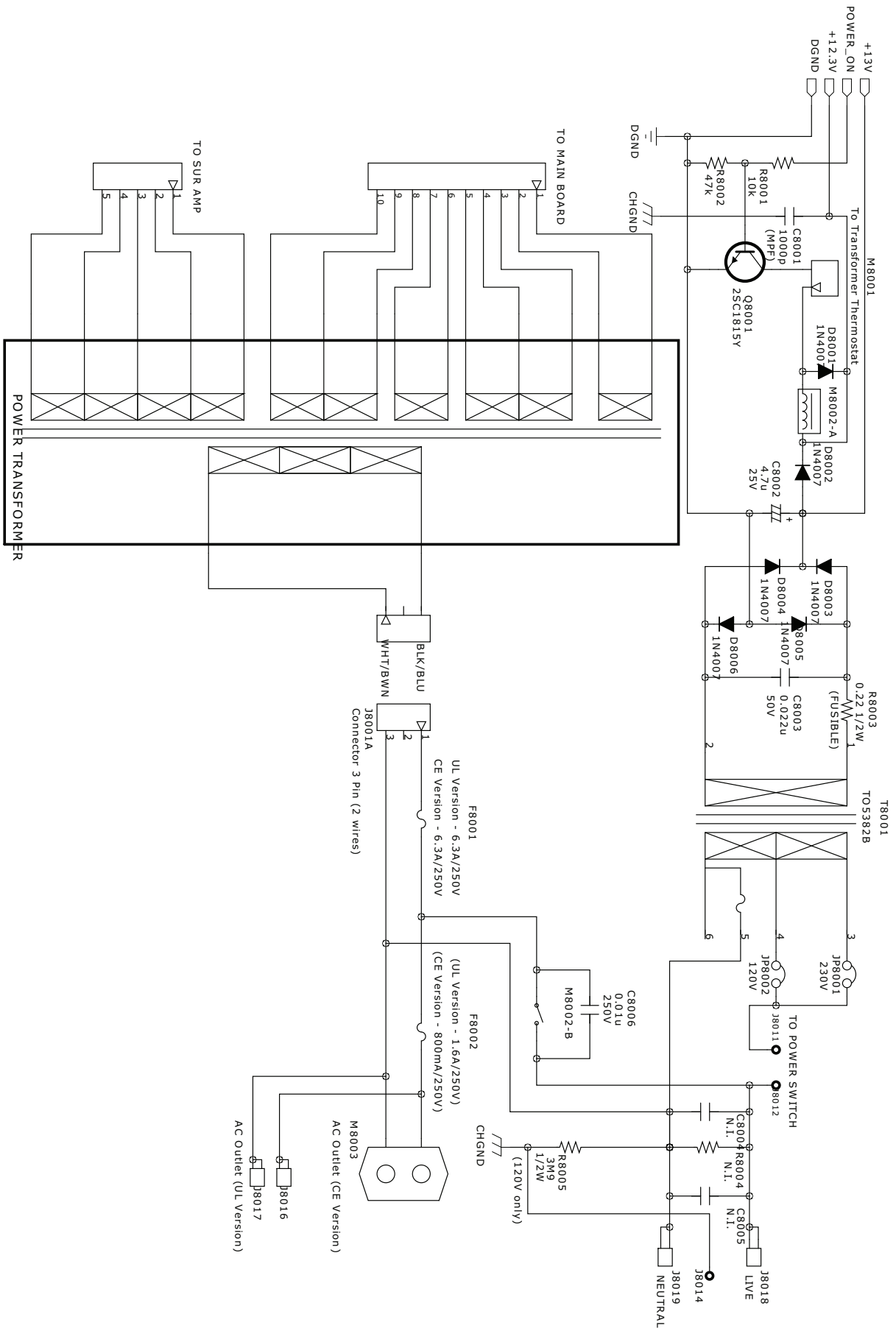

SPEAKER

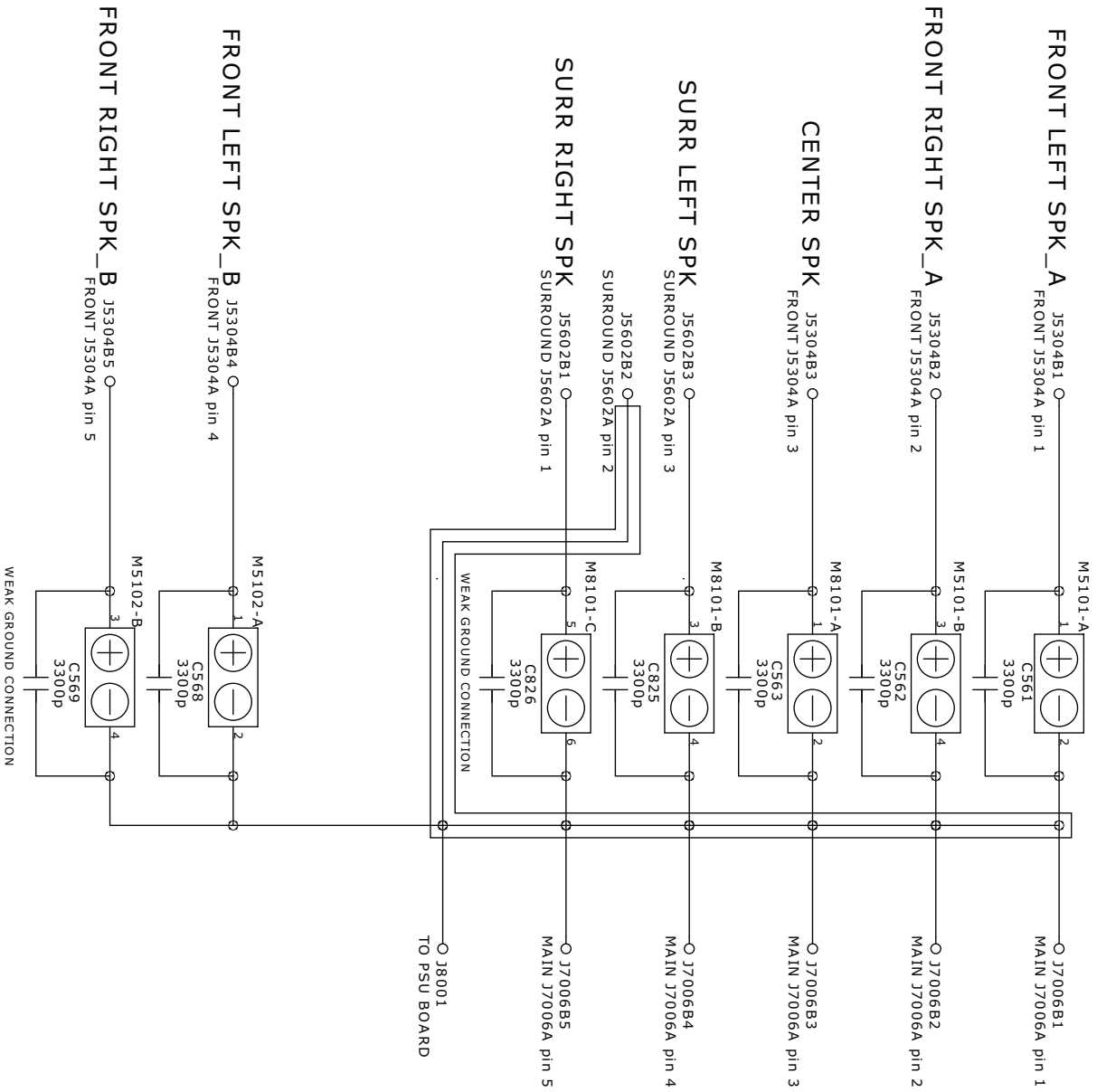

F-VIDEO

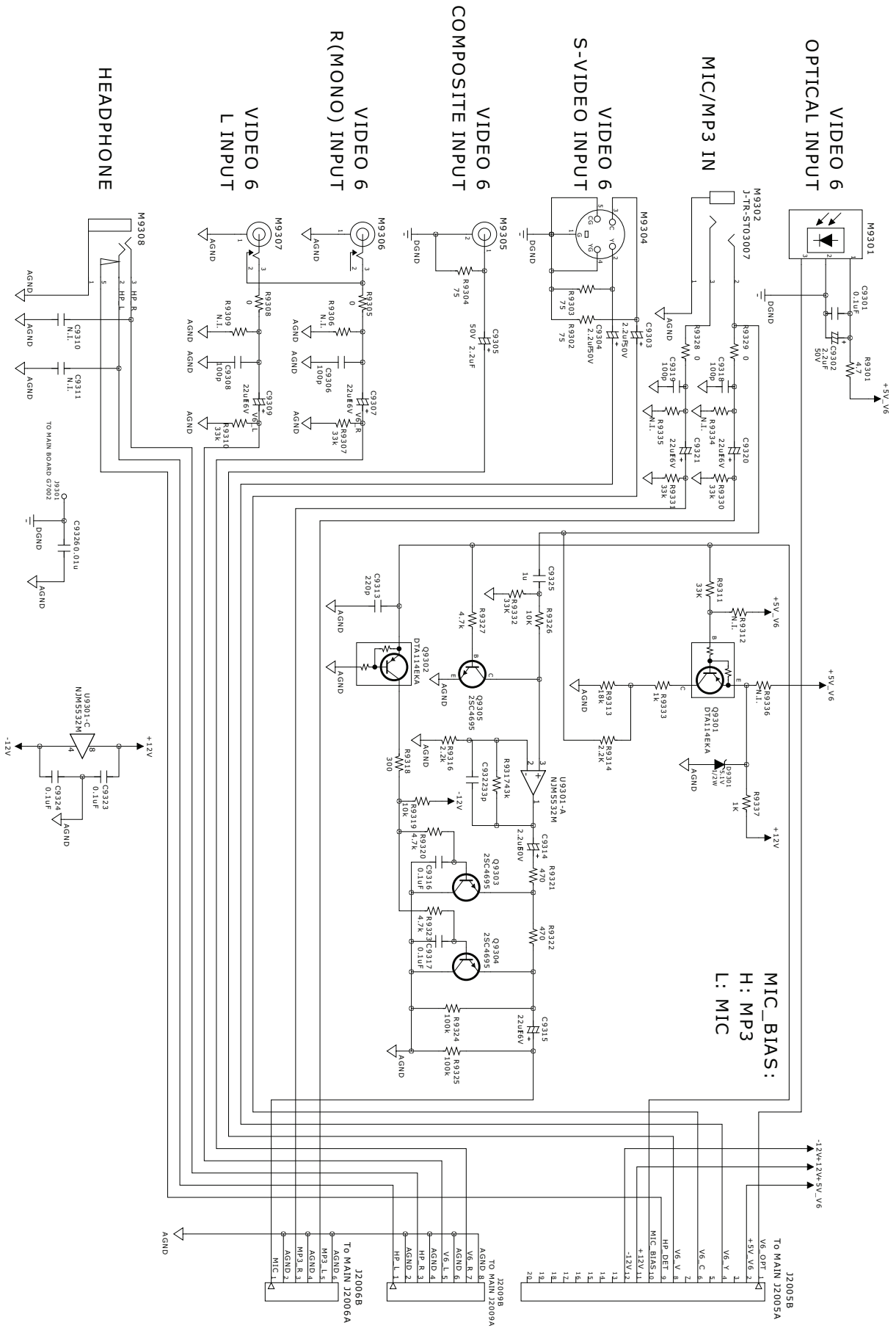

DSP-1

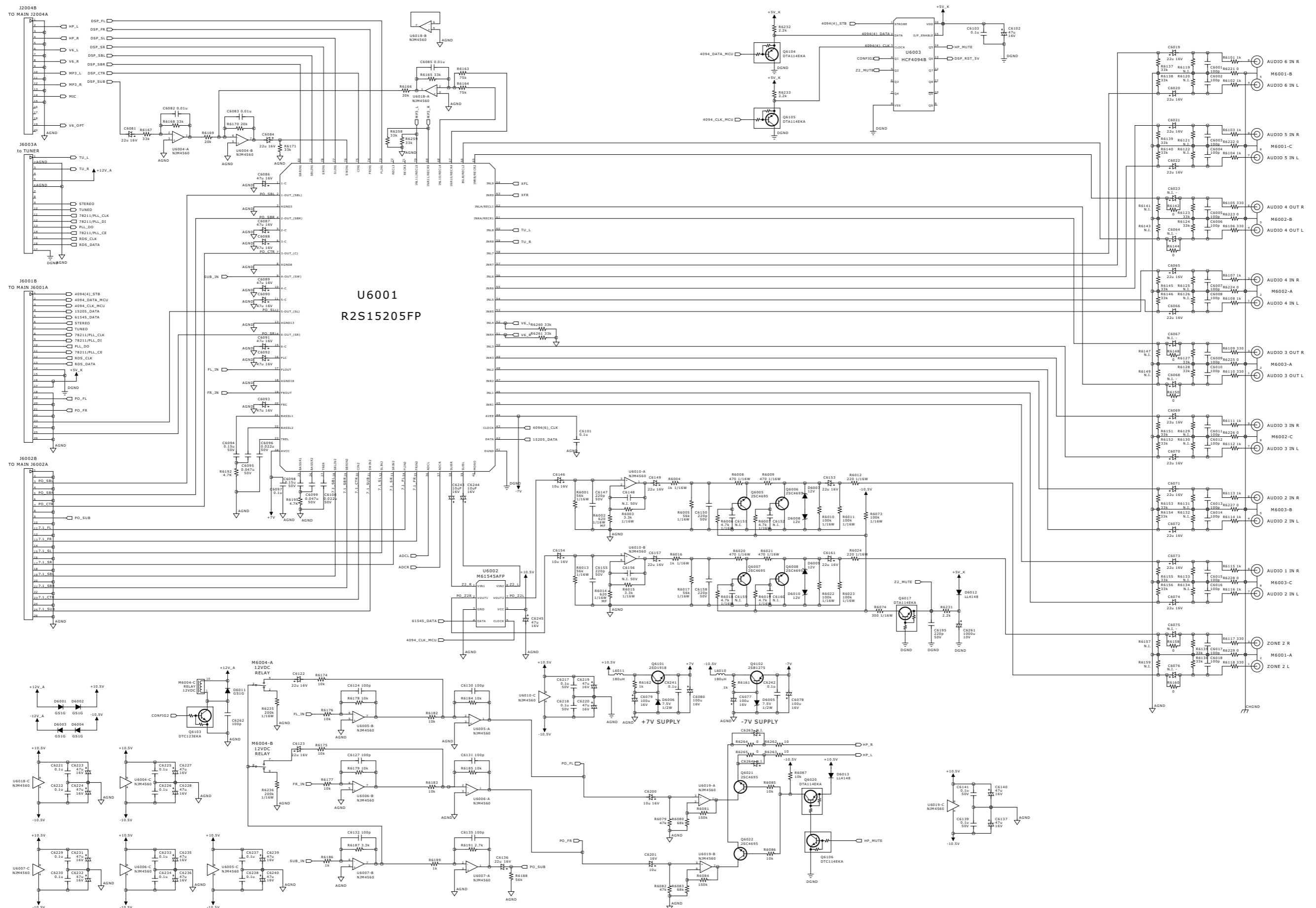

DSP-2

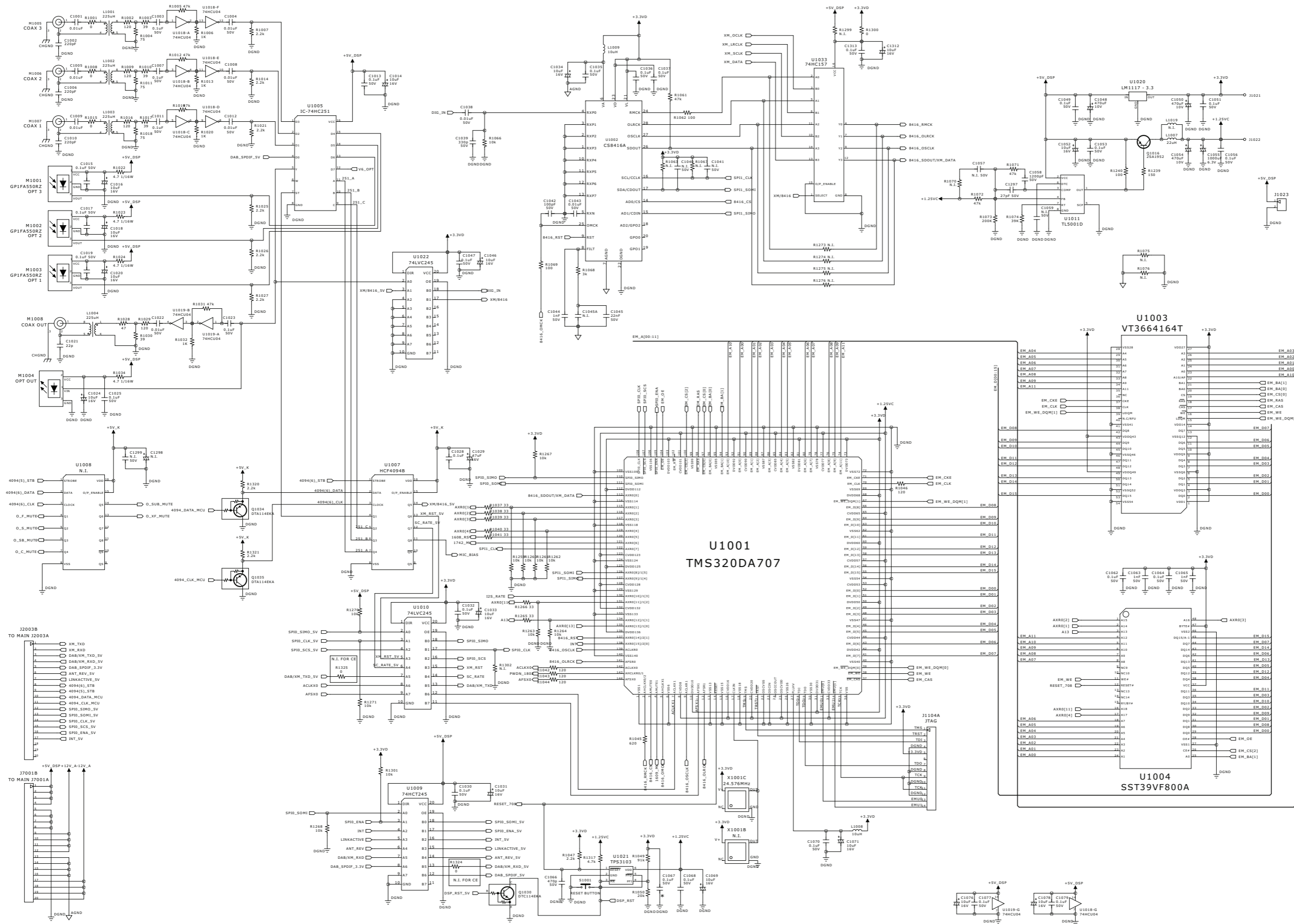

DSP-3

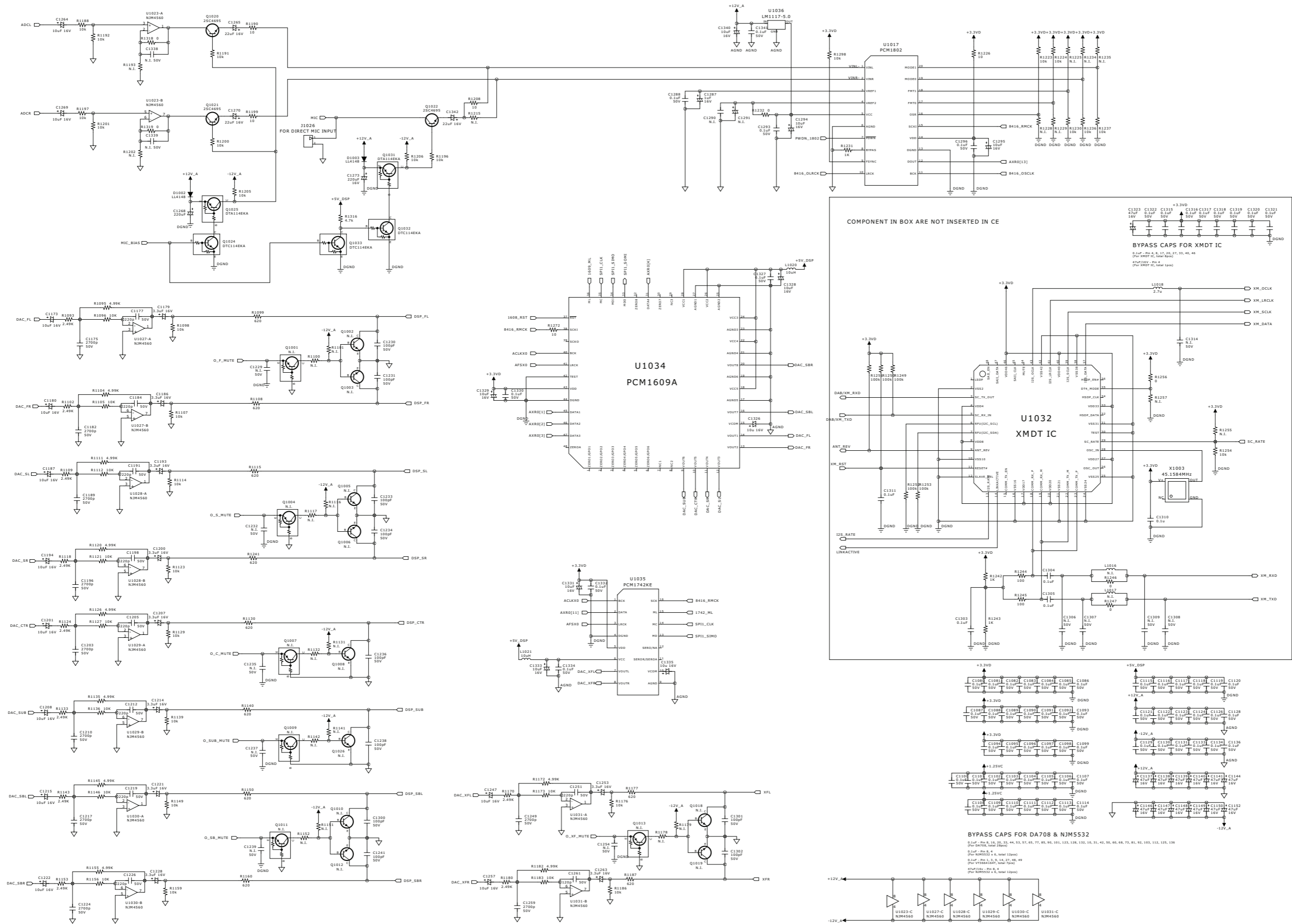

KEYBOARD

VD2201
VFD-16-BT-130GINK

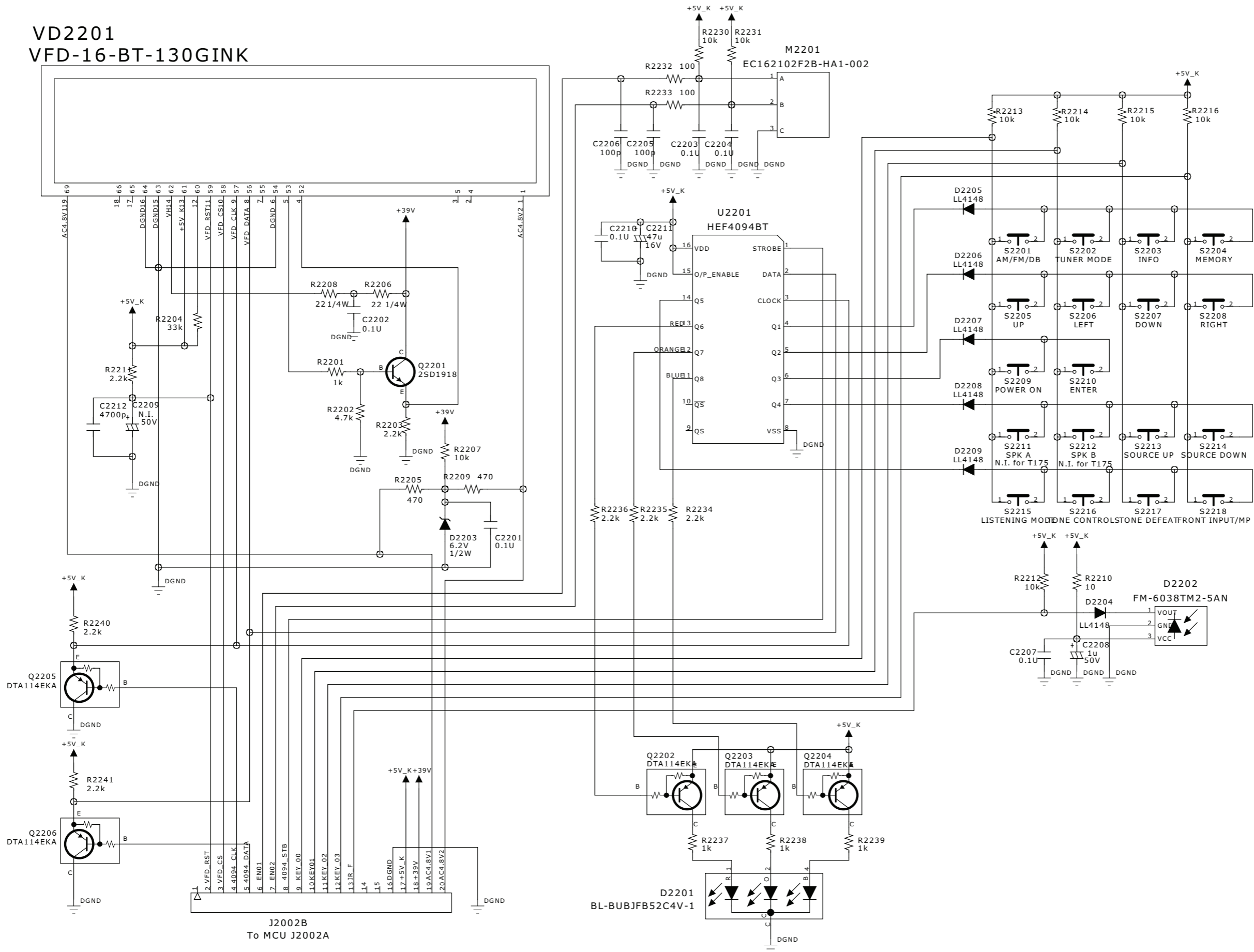

POWER AMPLIFIER FRONT-CH

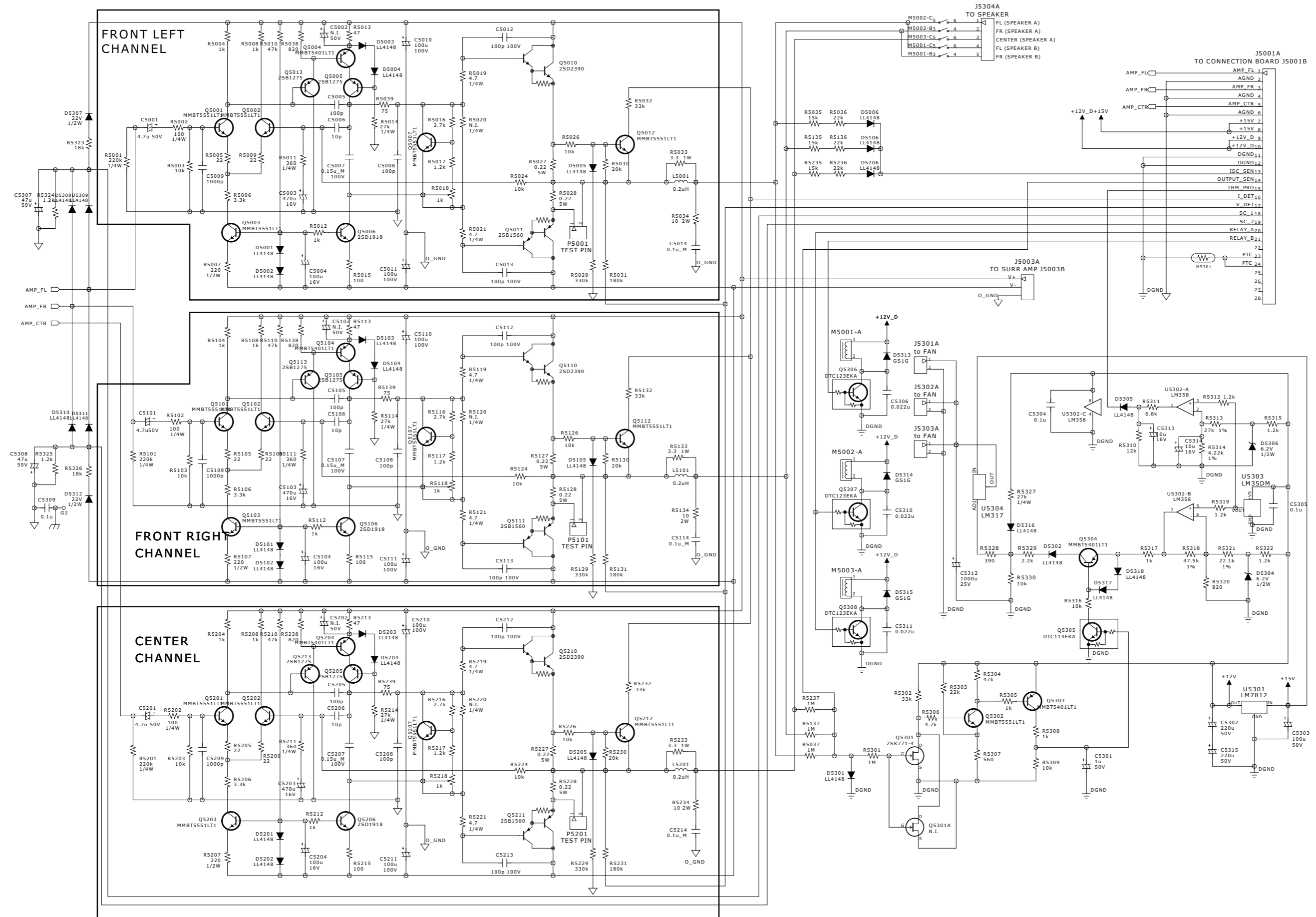

POWER AMPLIFIER SURROUND-CH-1

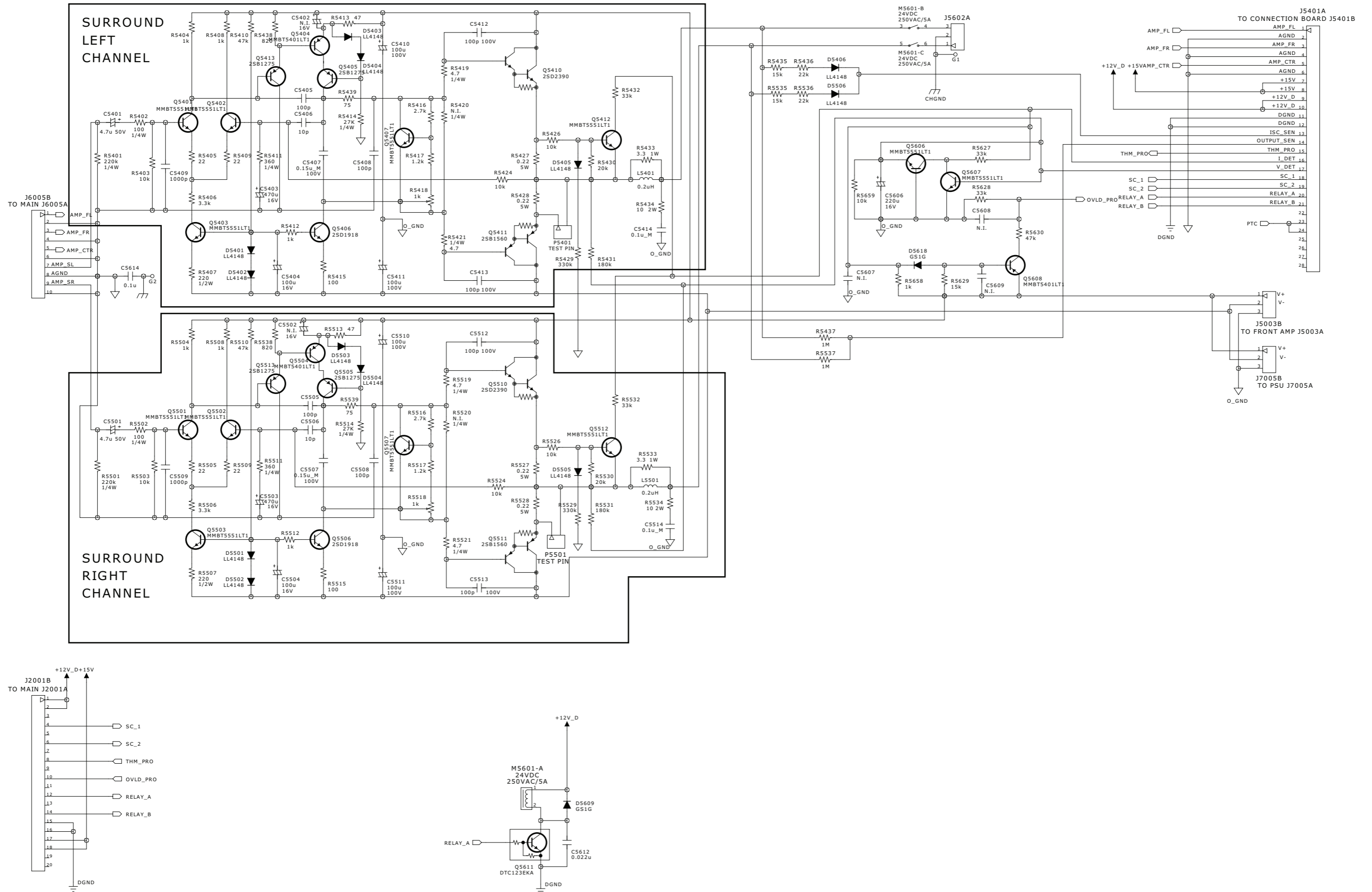

POWER AMPLIFIER SURROUND-CH-2

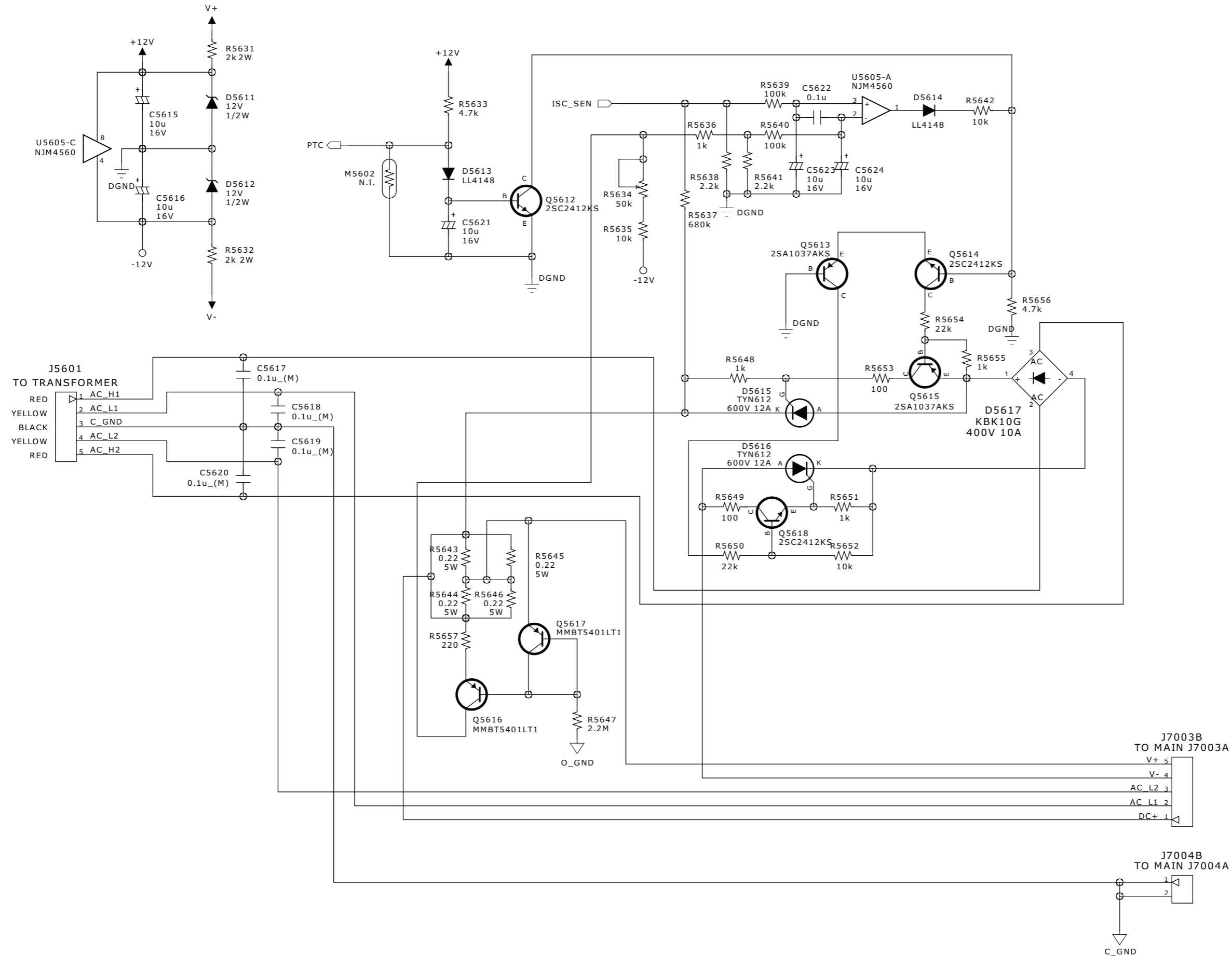

HDMI

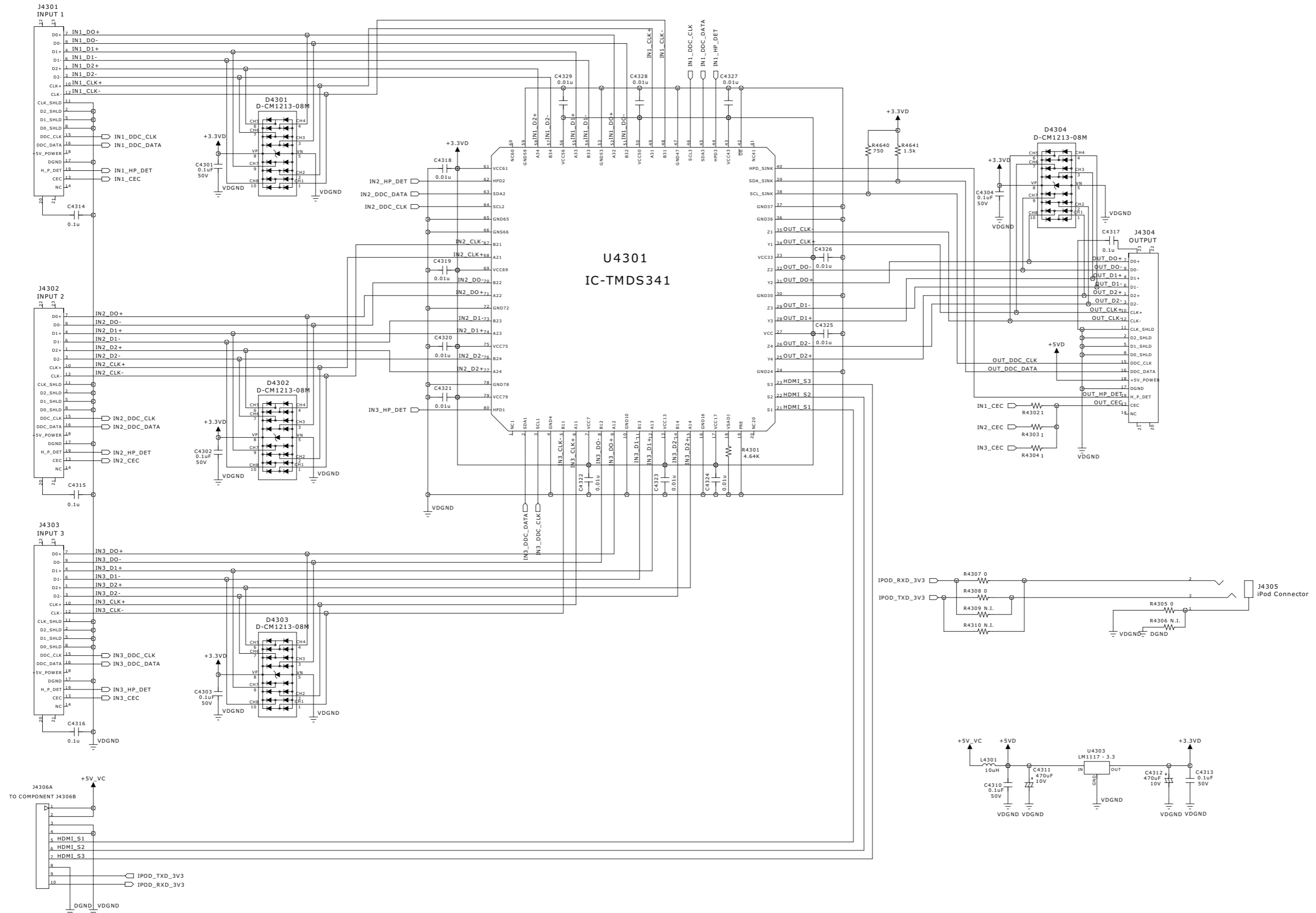

TRIGGER

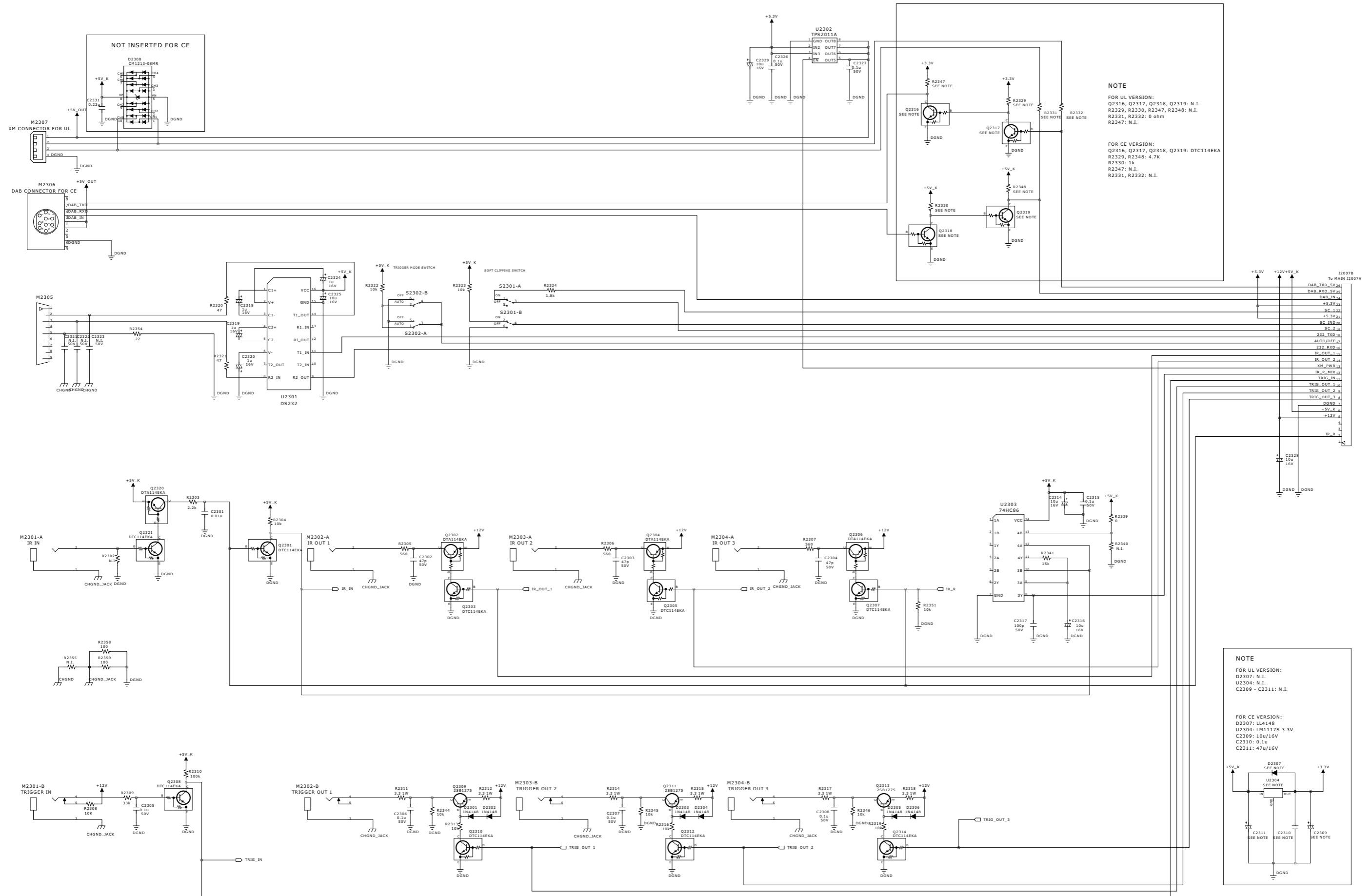

COMPONENT VIDEO

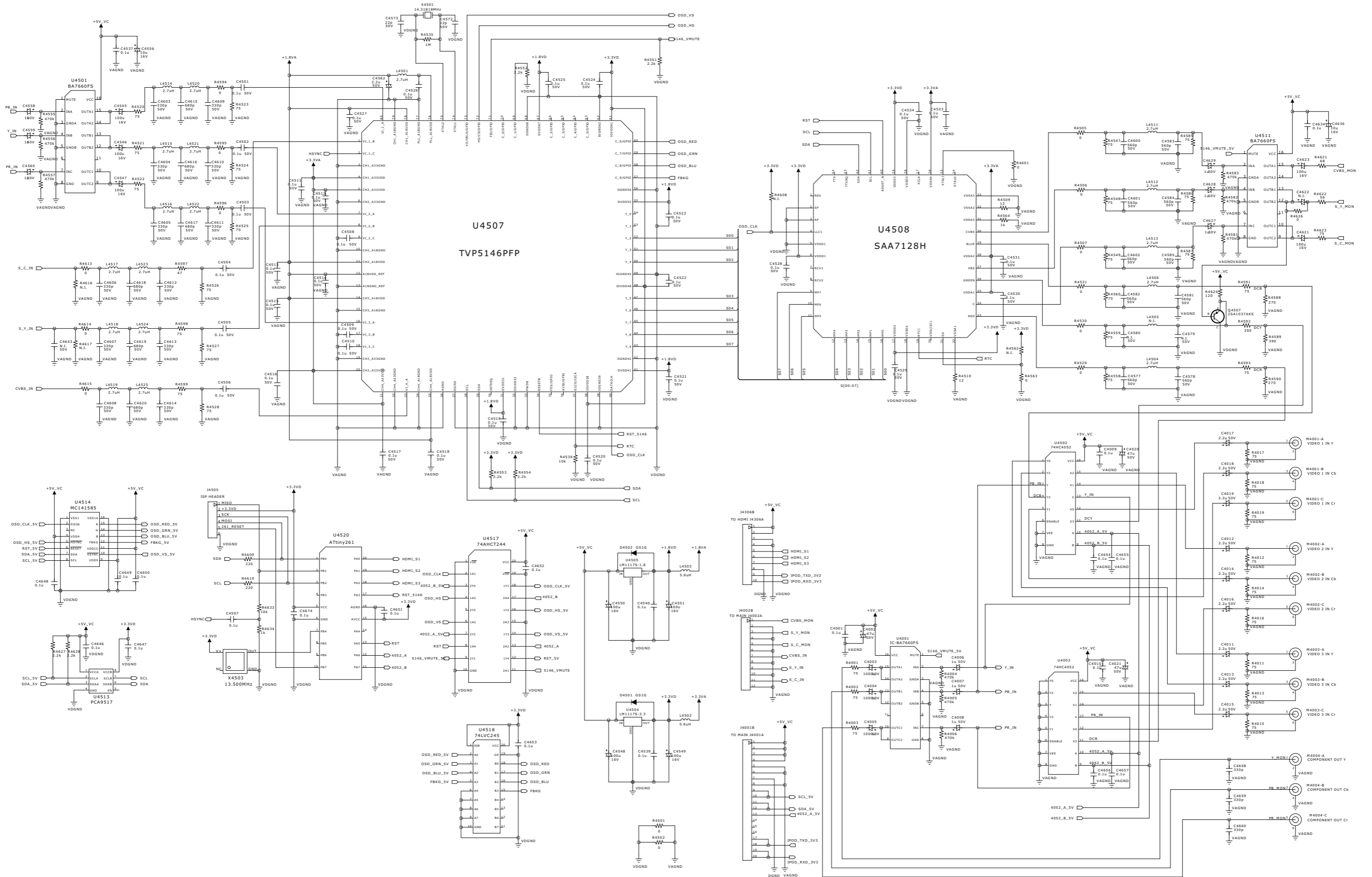

MAIN BOARD-1

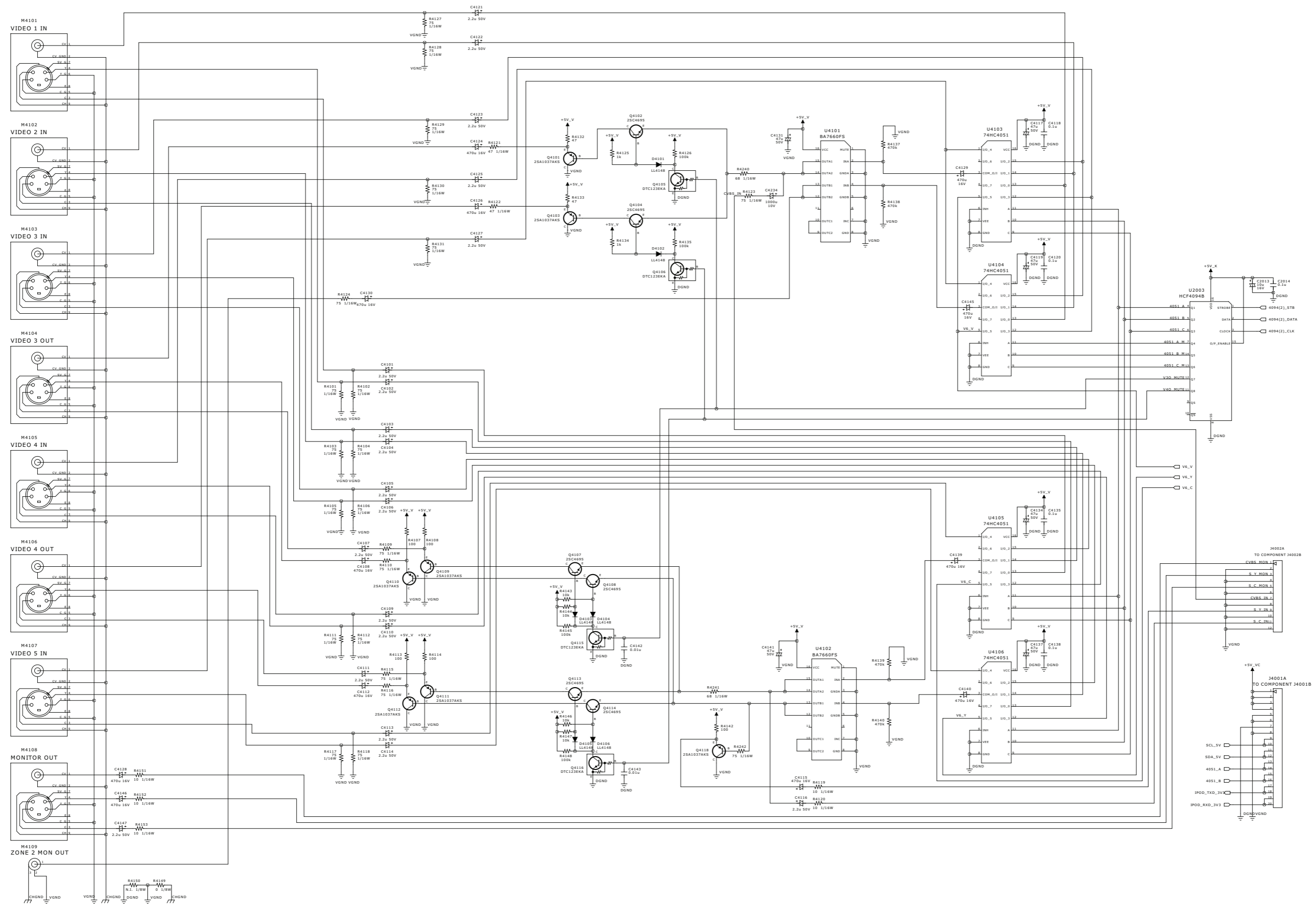

MAIN BOARD-2

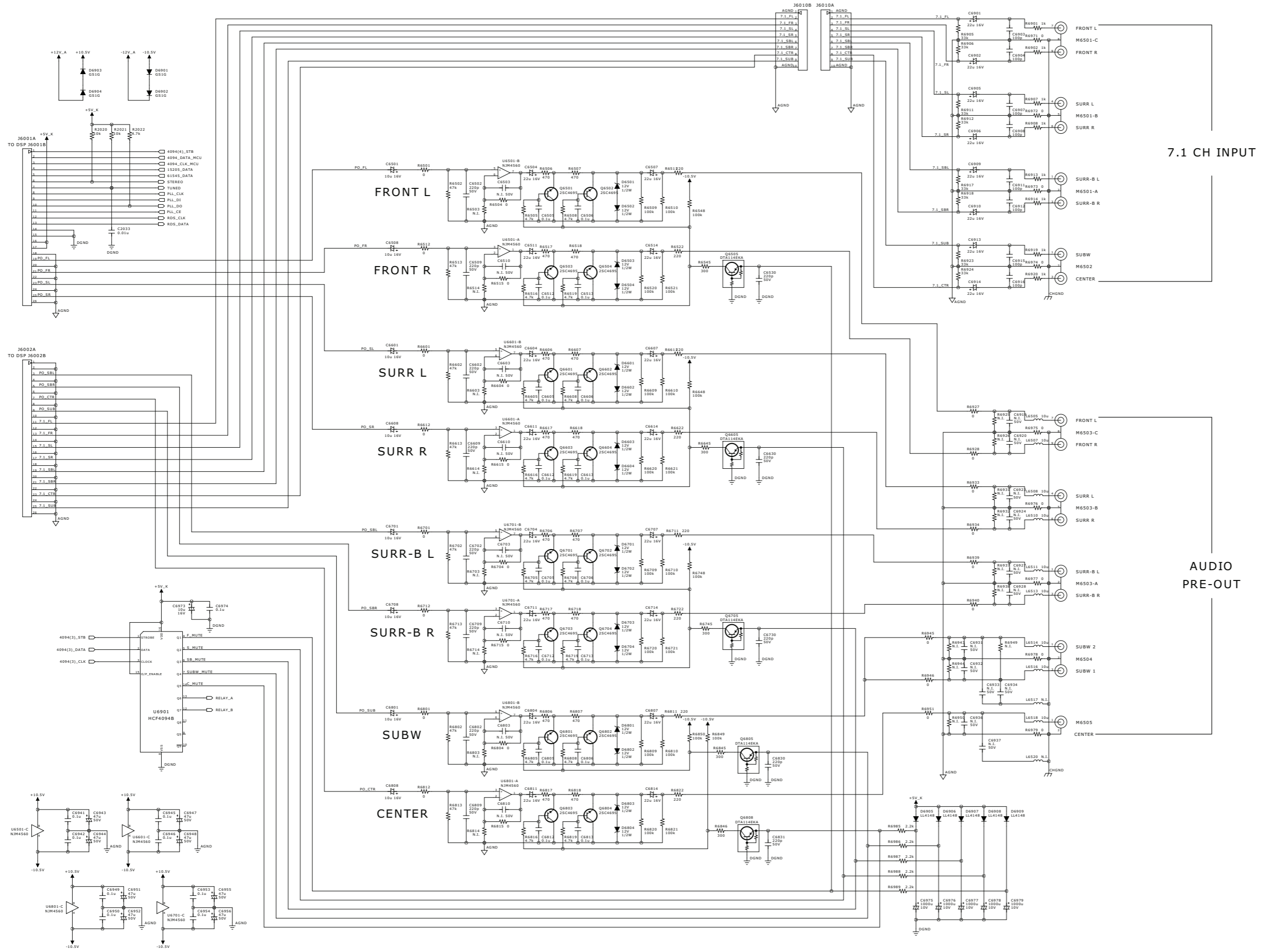

MAIN BOARD-3

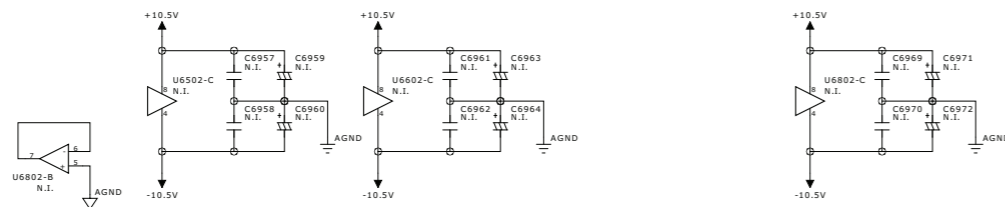
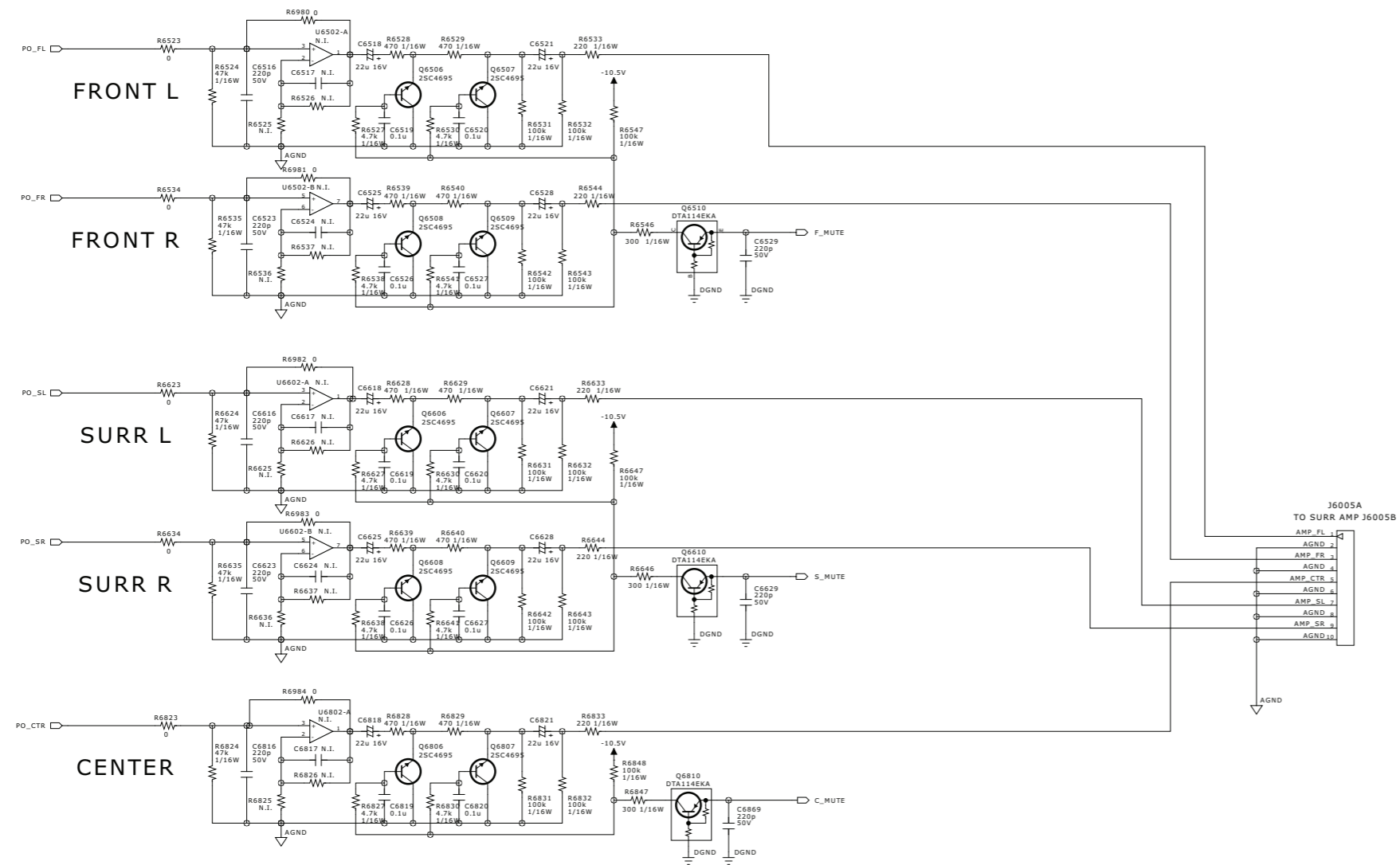

MAIN BOARD-4

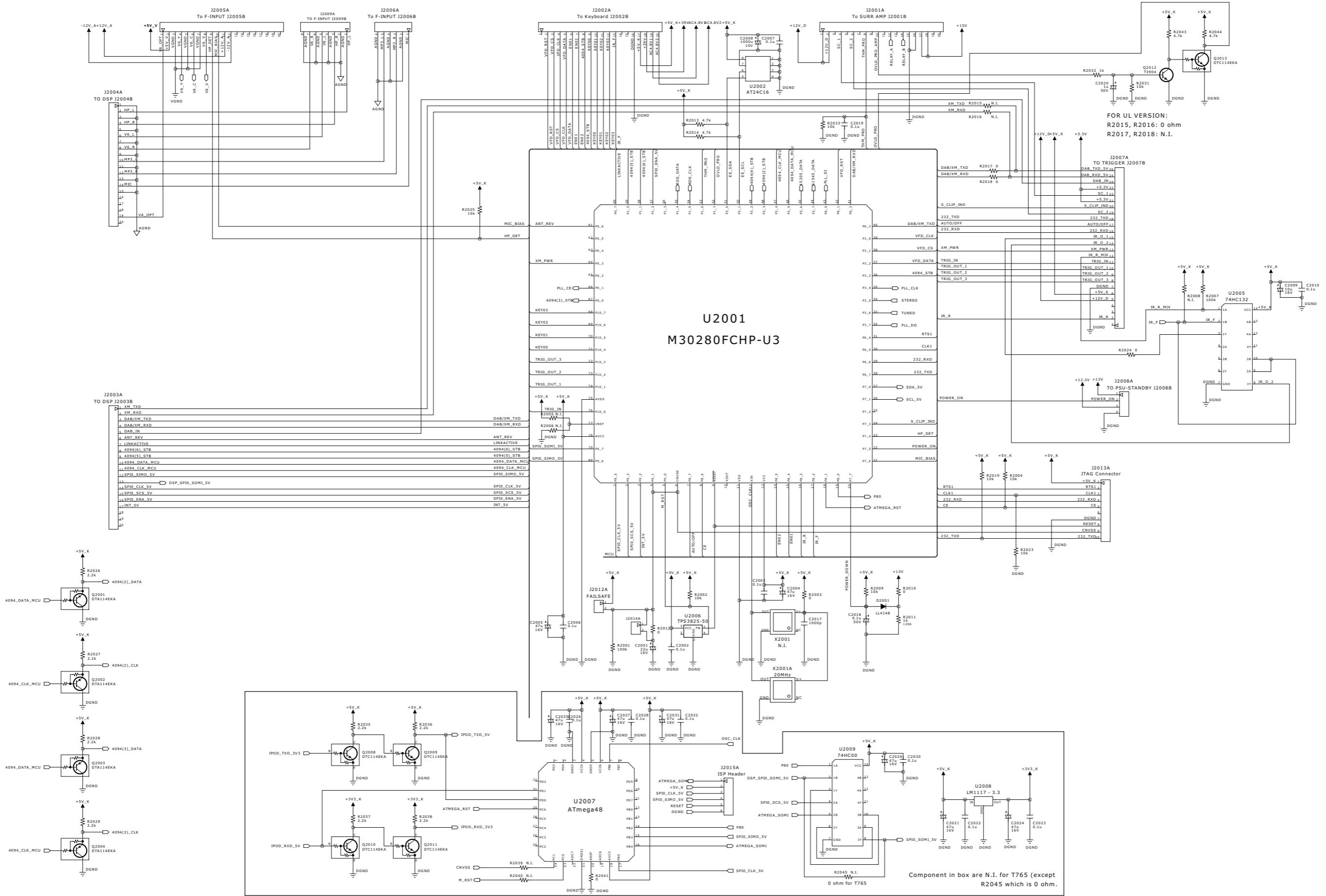

MAIN BOARD-5

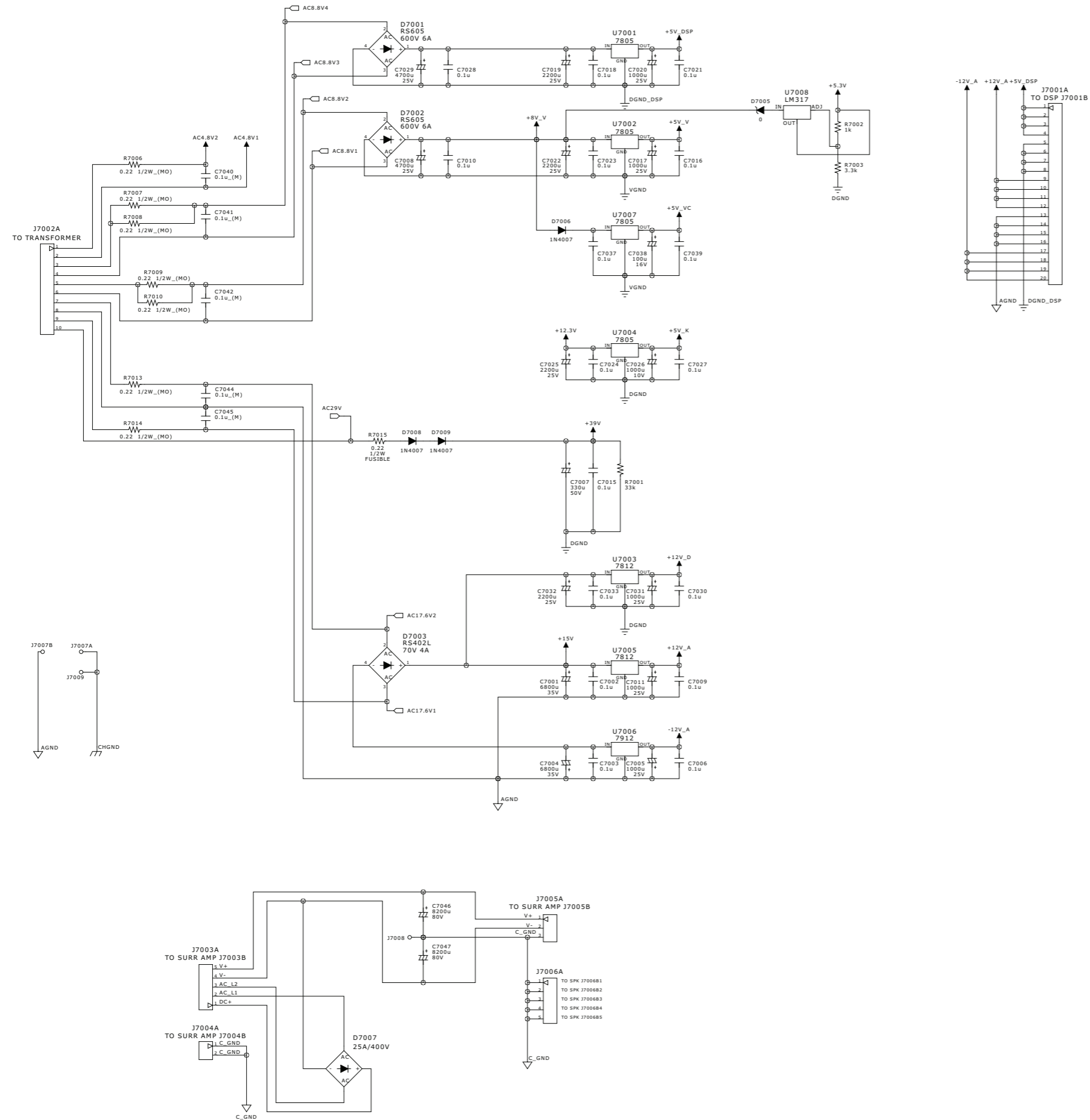

ELECTRICAL PARTS LIST

POWER AMP MODULE ***SEE PAGE 92 FOR SINGLE CHANNEL SERVICE KIT # 52-940-0755-90		
PCB ASSEMBLY	50-940-0755-90	T755 PWR AMP MODULE
MAIN BOARD		
PCB ASSEMBLY*AH	50-901-0755-90	T755 AH MAIN ASSY
PCB ASSEMBLY*C,CT	50-902-0755-90	T755 C/CT MAIN ASSY
REGULATORS		
U7001-7002 U7004 U7007	01-004-0048-00	IC VOLT REG 5V 1A TO-220 NJM7805FA
U7003 U7005	01-004-0049-00	IC VOLT REG 12V 1A TO-220 NJM7812
U7006	01-004-0051-00	IC VOLT REG TO-220F NJM7912
U7008	01-004-0054-90	IC REG 1A TO-220(T) LM317T
RESISTORS		
R7015	02-004-0014-00	RES FUSIBLE 0.22 OHM 10% 1/2W AXIAL
R7006-7010 R7013-7014	02-010-0011-00	RES MO 0.22 OHM 5% 1/2W AXIAL
CAPACITORS		
C7008 C7029	03-002-0057-00	E CAP 4700uF/25V 105°C
C7005 C7011 C7017 C7020 C7031	03-002-0066-00	E CAP 1000uF/25V ±20% 105°C
C7038	03-002-0133-00	CAP ELEC SS 100uF 16V 20% 85C
C7019 C7022 C7025 C7032	03-002-0151-00	CAP ELEC 2200uF 25V 20% 105C
C7007	03-002-0153-00	CAP ELEC 330uF 50V +/-20% 85C
C7001 C7004	03-002-0160-00	CAP ELEC SK 6800uF 35V 20% 105C
C7046-7047	03-002-0174-90	E CAP 8200uF/80V 85 ±20%
C7040-7042 C7044-7045	03-004-0031-00	MPF CAP 104J/63V 5% Mini Box
DIODES		
D7006 D7008-7009	04-001-0003-00	Diode 1N4007 DO-41 1A/1000V
D7007	04-005-0017-00	Bridge Rectifier KBK25G 25A/400V
D7003	04-005-0020-90	DIODE BRI 4A/70V RS402
D7001 D7002	04-005-0022-90	DIODE BRI 6A/600V RS605
RCA JACKS		
M6502 M6504	15-003-0022-90	RCA JACK 2 B/B PCB MOUNT GOLD RS-213G-02(W)
M4101-4108	15-003-0032-90	RCA JACK 1 YELLOW & S-VIDEO PCB MOUNT W/COVER
M6505	15-003-0036-90	RCA JACK 1 BLACK PCB MOUNT GOLD W/O COVER
M4109	15-003-0037-90	RCA JACK 1 Y PCB MOUNT GOLD W/ COVER
M6501 M6503 MOUNT	15-003-0046-90	RCA JACK 6 W-W-W/R-R-R PCB GOLD W/O SHIELD
JUMPER		
D7005	17-016-0080-90	Jumper Wire Dia. 0.5mm For L Smaller than 14mm
SMD ICS		
U2008	01-004-0056-90	IC VOLT REG LOW DROPOUT 3.3V 1A SOT-223 LM1117S-3.3
U2006	01-008-0007-90	IC AME8530AEEVEFX29Z MICROPOWER UP WATCH DOG TIMER 2.93V SOT-25

U2001	01-010-0025-90	IC M30280FCHP-U3 16-BIT MCU 128K ROM 12K RAM QFP 80P6Q-A
U2007	01-010-0030-90	IC MCU 8 BITS 8K ROM 512 BYTES RAM TQFP ATmega48-20
U2002	01-011-0034-90	IC TWO-WIRE SERIAL EEPROM 16K AT24C16AN-10SU-2.7 SMD 8PIN SOIC
U2009	01-012-0059-00	IC Logic Quad 2-Input Nand Gate Sop 74HC00D
U4103-4106	01-012-0062-00	IC Logic 8-Channel Analog Mux/Demux SMD 74HC4051D
U2003 U6901	01-012-0065-00	IC Logic 8-Stage Shift-And-Store Bus Register SMD SO16 HEF4094BT
U2005	01-012-0073-90	IC SN74HC132DT LOGIC QUAD NAND GATES W/SCHMITT-TRIGGER SMD 14 PINS SOIC
U6501 U6601 U6701 U6801	01-014-0027-00	IC NJM4560M SO-8 JRC Dual Operational Amplifier
U4101-4102	01-026-0001-90	IC Video 3-Channel 75 OHM Driver Ssop BA7660FS
SMD RESISTORS		
R6907-6908 R6919-6920 R6913-6914	02-007-0042-00	RES SMD 1K OHM 0603 5%
R4134 R6901 R4125 R6902 R2032		
R4149 R2010 R6971-6979	02-007-0089-00	RES SMD 0 OHM 1/8W 0805 5%
R2011	02-007-0094-00	RES SMD 1K OHM 1/4W 1206 1%
R6905-6906 R6911-6912 R6917-6918	02-007-0136-00	RES SMD 33K OHM 0603 5%
R6923-6924		
R2022 R2043 R2044 R6538 R6638 R6641	02-007-0139-00	RES SMD 4.7K OHM 0603 5%
R6505 R6516 R6705 R6616 R6708 R6608		
R6619 R6716 R6719 R6541 R6519 R6805		
R6808 R2013 R2014 R6816 R6819 R6827		
R6627 R6830 R6508 R6605 R6527 R6630		
R6530		
R6502 R6513 R6602 R6613 R6702 R6713	02-007-0140-00	RES SMD 47K OHM 0603 5%
R6802 R6813 R6524 R6535 R6624 R6635		
R6824		
R4142	02-007-0141-00	RES SMD 100 OHM 0603 5%
R4121 R4122 R4132 R4133	02-007-0146-00	RES SMD 47 OHM 0603 5%
R4119-4120 R4151-4153	02-007-0151-00	RES SMD 10 OHM 0603 5%
R4143-4144 R4146-4147 R2002	02-007-0157-00	RES SMD 10K OHM 0603 1%
R2009 R2019-2021 R2023 R2025		
R2031 R2033 R2004		
R2001 R2007 R4126 R4135 R4145	02-007-0267-00	RES SMD 100K OHM 5% 1/16W 0603
R4148 R6509-6510 R6520-6521		
R6531-6532 R6542-6543 R6547-6548		
R6609-6610 R6620-6621 R6609-6610		
R6620-6621 R6631-6632 R6642-6643		
R6647-6648 R6709-6710 R6720-6721		
R6748 R6809-6810 R6820-6821		
R6831-6832 R6848-6850		
R6501 R6504 R2003 R6512 R6515	02-007-0288-00	RES SMD 0 OHM 5% 1/16W 0603
R2012 R6601 R6604 R2015-2016*AH		
R2017-2018*C,CT R6612 R6615 R2024		
R6701 R6704 R6712 R6715 R6801 R6804		
R6812 R6815 R2041 R6927-6928		
R6933-6934 R6939-6940 R6945-6946		
R6951 R6534 R6523 R6980-6984 R6823		
R6634 R6623		

R4240-4241	02-007-0289-00	RES SMD 68 OHM +/-1% 1/16W 0603
R2026-2029 R2035-2038 R6985-6989	02-007-0292-00	RES SMD 2.2K OHM 1% 1/16W 0603
R6606-6607 R6617-6618 R6628-6629	02-007-0294-00	RES SMD 470 OHM 5% 1/16W 0603
R6639-6640 R6539 R6706-6707 R6540		
R6517-6518 R6717-6718 R6507		
R6806-6807 R6817-6818 R6828-6829		
R6528-6529 R6506		
R7002	02-007-0306-00	RES SMD 1K OHM 1% 1/16W 0603
R6546 R6645-6646 R6745 R6545	02-007-0319-00	RES SMD 300 OHM 5% 1/16W 0603
R6845-6847		
R7003	02-007-0321-00	RES SMD 3.3K OHM 1% 1/16W 0603
R7001	02-007-0347-00	RES SMD 33K OHM 5% 1/10W 0805
R4137-4140	02-007-0352-00	RES SMD 470K OHM 5% 1/16W 0603
R4118 R4123-4124 R4127-4131	02-007-0357-00	RES SMD 75 OHM 5% 1/16W 0603
R4101-4102 R4242 R4103-4106		
R4109-4112 R4115-4117		
R4107-4108 R4113-4114	02-007-0358-00	RES SMD 100 OHM 5% 1/10W 0805
R6533 R6544 R6611 R6511 R6622	02-007-0372-00	RES SMD 220 OHM 5% 1/16W 0603
R6633 R6644 R6711 R6722 R6811		
R6522 R6822 R6833		

SMD CAPACITORS

C2002-2003 C2006-2007 C2010 C2014	03-009-0075-00	CAP CER CAP 0.1uF/50V 20% Y5V 0603
C2019 C2022-2023 C2026 C2028 C2030		
C2032 C4118 C4120 C4135 C4138		
C6941-6942 C6945-6946 C6949-6950		
C6953-6954 C6974 C7002-7003 C7006		
C7009-7010 C7015-7016 C7018 C7021		
C7023-7024 C7027-7028 C7030 C7033		
C7037 C7039		
C6908 C6903 C6911-6912	03-009-0111-00	CAP CER SMD 100pF 50V 10% X7R 0603
C6915-6916 C6904 C6907		
C2017	03-009-0112-00	CAP CER SMD 1nF 50V 10% X7R 0603
C2033 C4142 C4143	03-009-0113-00	CAP CER SMD 10nF 50V 10% X7R 0603
C6809 C6816 C6609 C6830-6831 C6869	03-009-0114-00	CAP CER SMD 220pF 50V 10% X7R 0603
C6502 C6516 C6616 C6623 C6523		
C6629-6630 C6702 C6709 C6509 C6529		
C6730 C6802 C6530 C6602		
C6808 C6708 C6608 C6701 C6801 C6508	03-009-0136-00	CAP ELEC SMD 10uF 16V +/-20% 4 x5.4
C2013 C6601 C2009 C6501 C6973		
C2008 C4234 C6975-6979 C7026	03-009-0138-00	CAP ELEC SMD 1000uF 10V +/-20% 10x10.5
C2018	03-009-0139-00	CAP ELEC SMD 0.1uF 50V +/-20% 4x5.4
C6504 C6507 C6511 C6514 C6518 C6521	03-009-0140-00	CAP ELEC SMD 22uF 16V +/-20% 5x5.4
C6525 C6528 C6604 C6607 C6611 C6614		
C6618 C6621 C6625 C6628 C6704 C6707		
C6711 C6714 C6804 C6807 C6811 C6814		
C6818 C6821 C6901-6902 C6905-6906		
C6909-6910 C6913-6914 C2001		
C4122-4123 C4125 C4127 C4105-4107	03-009-0141-00	CAP ELEC SMD 2.2uF 50V +/-20% 4x5.4
C4109-4111 C4147 C4101 C4113-4114		
C4102 C4116 C4103-4104 C4121		
C2027 C2029 C2031 C2004-2005 C4117	03-009-0143-00	CAP ELEC SMD 47uF 50V +/-20% 6.3x7.7
C4119 C4131 C4134 C4137 C2021 C2024		
C4141 C2025 C6943-6944 C6947-6948		
C6951-6952 C6955-6956		

C4108 C4112 C4115 C4124 C4126 C4128-4130 C4139-4140 C4145 C4146 C2020	03-009-0144-00 03-009-0153-00	CAP ELEC SMD 470uF 16V +/-20% 10x10.5 CAP ELEC 1uF/50V ±20% B CASE 4 X 5.4
SMD DIODES		
D6901-6904	04-006-0019-00	SMD Diode RECT 1A/400V DO-214AC GS1G M4 GS1G
D2001 D4101-4106 D6905-6909	04-006-0021-90	SMD DIODE LL4148 SOD80
D6501-6504 D6601-6604 D6701-6704 D6801-6804	04-007-0039-90	DIODE ZENER SMD 12V 500mW 5% SOD123 MM1Z12
SMD TRANSISTORS		
Q4102 Q4104 Q4107-4108 Q4113-4114 Q6501-6504 Q6506-6509 Q6601-6604 Q6606-6609 Q6701-6704 Q6801-6804 Q6806-6807	05-004-0017-00	SMD Transistor 2SC4695 NPN SOT-23
Q2012	05-004-0020-00	SMD Transistor T3904 SOT-23
Q4101 Q4103 Q4109-4112 Q4118	05-004-0034-90	TRANSISTOR 2SA1037AKS PNP HFE 270-560 140MHz SMD SMT3
Q2008-2011 Q2013	05-004-0035-90	TRANSISTOR SS NPN HFE30 250MHz SPT DTC114EKAT146
Q4115-4116 Q4105-4106	05-004-0036-90	TRANSISTOR SS NPN HFE20 250MHz DTC123EKAT146
Q2001-2004 Q6505 Q6510 Q6605 Q6610 Q6705 Q6805 Q6808 Q6810	05-004-0037-90	TRANSISTOR SS PNP HFE30 250MHz SPT DTA114EKAT146
SMD INDUCTORS		
L6507 L6513-6514 L6508 L6516 L6505 L6518 L6510-6511	07-007-0019-90	IND SMD 10uH +/-10% 0805 YT201212T-100K-S
SMD OSCILLATOR		
X2001A	14-004-0019-90	CRYSTAL OSCILLATOR 20.000MHz 5V 50ppm 15pF SMD
PSU BOARD		
PCB ASSEMBLY*AH	50-903-0755-90	T755AH PSU ASSY
PCB ASSEMBLY*C,CT	50-904-0755-90	T755 C/CT PSU ASSY
RESISTORS		
R8005*AH	02-001-0451-00	RES CONDUCTIVE PATH 3.9M OHM 1/2W 5% 250V
R8003	02-004-0014-00	RES FUSIBLE 0.22 OHM 10% 1/2W
CAPACITORS		
C8003	03-001-0065-00	CAP CER KK 0.022uF 50V 10% Z5U ST5
C8002	03-002-0148-00	CAP ELEC SS 4.7uF 50V 20% 85C
C8001	03-004-0115-00	CAP MpF 0.001uF 63V 5% DMF 5 SERIES
C8006	03-007-0014-00	HC CER CAP 0.01uF/250VAC ±20% UL/CSA/VDE
DIODES		
D8001-8006	04-001-0003-00	Diode 1N4007 DO-41 1A/1000V
TRANSISTORS		
Q8001	05-001-0072-00	Transistor SS NPN HEF 100 200MHs TO-92 C1815Y

RELAYS

M8002*AH	07-005-0056-90	RELAY POWER DC 12V 20A 220VAC ME-14FW-012-HTS UL/CUL
M8002*C,CT	07-005-0044-90	RELAY MINIATURE 12VDC/10A 1P1T TV-5 SDT-SS-112DM S/CSA/UL

STANDBY-TRANSFORMER

T8001	10-005-0186-90	Transformer PW EL-35 100V/220V T05382B
-------	----------------	---

FUSES

F8001	20-001-0072-90	FUSE TIME-LAG 6.3A 250VAC 5X20mm TSD UL/CSA/VDE/CCC
F8002	20-001-0076-90	FUSE 1.6A 250V TIME LAG LBC 5X20mm TSD UL/CSA/VDE/SEMKO
F8002*C,CT	20-001-0069-90	FUSE TIME-LAG 800mA 250V 5x20mm TSD UL/CSA/VDE/CCC
FH8001, FH8002	20-002-0030-90	FUES CLIP 5.2X20mm WL-210A 10A 250V

JUMPERS

JMP1-JMP3	17-016-0077-00	Jumper wire Dia. 0.5mm L=52.0mm
JP8002*AH JP8001*C,CT	17-016-0080-90	Jumper Wire Dia. 0.5mm For L Smaller than 14mm

FRONT POWER AMP BOARD *SEE PAGE 92 FOR SINGLE CHANNEL SERVICE KIT # 52-940-0755-90**

PCB ASSEMBLY	NSP	T755 Front Amp Board Assembly NSP
---------------------	------------	--

IC & REGULATOR

U5301	01-004-0049-00	IC VOLT REG 12V 1A TO-220 NJM7812
U5304	01-004-0054-90	IC REG 1A TO-220(T) LM317T
U5303	01-020-0026-90	IC LM35DT TEMP SENSOR TO-220

RESISTORS

R5027-5028 R5127-5128 R5227-5228	02-005-0063-00	RES WW 0.22 OHM 5% 5W AXIAL
R5034 R5134 R5234	02-010-0014-00	RES MO 10 OHM 5% 2W AXIAL

CAPACITORS

C5312	03-002-0066-00	E CAP 1000uF/25V ±20% 105°C 10x20mm
C5010 C5011 C5110 C5111 C5210 C5211	03-002-0134-00	CAP ELEC GR 100uF 100V 20%
C5114 C5014 C5214	03-004-0031-00	MPF CAP 104J/63V 5% Mini Box
C5007 C5107 C5207	03-004-0123-00	MPF CAP 0.15uF/100V/154J 5%Mini Box

TRANSISTORS

Q5011 Q5111 Q5211	05-001-0100-90	TRANSISTOR PW DARLINGTON PNP 10A/150V TO-3PB 2SB1560
Q5010 Q5110 Q5210	05-001-0101-90	TRANSISTOR PW DARLINGTON NPN 10A/150V TO-3PB 2SD2390

VARIABLE RESISTORS

R5018 R5118 R5218	06-004-0016-90	VR SEMI-FIX RES CF 1K OHM B 30% 6mm
-------------------	----------------	--

COILS

L5001 L5101 L5201	07-002-0136-90	AIR COIL 0.2uH 10% 1 X 9 X 13.5 TURNS
-------------------	----------------	--

RELAYS

M5001-5003	07-005-0055-90	RELAY POWER DC12V 8A/250V 2P1T PCB MOUNT ME-11-012-2H4
------------	----------------	---

THERMISTOR

M5301	20-004-0039-00	THERMISTOR PTC 100 OHM PTFM04B H471Q2N34B0
-------	----------------	---

SMD IC

U5302	01-014-0043-00	IC LOW POWER DUAL OPERATIONAL AMPLIFIERS SMD SOIC-8 AS358MTR-E1
-------	----------------	---

SMD RESISTORS

R5010 R5110 R5210 R5304	02-007-0026-00	RES SMD 47K OHM 5% 1/10W 0805
R5306	02-007-0028-00	RES SMD 4.7K OHM 5% 1/10W 0805
R5017 R5117 R5217 R5324 R5325		
R5312 R5315 R5319 R5322	02-007-0033-00	RES SMD 1.2K OHM 5% 1/10W 0805
R5031 R5131 R5231	02-007-0037-00	RES SMD 180K OHM 5% 1/10W 0805
R5311	02-007-0046-00	RES SMD 6.8K OHM 0805 5%
R5329	02-007-0058-00	RES SMD 2.2K OHM 0805 5%
R5318	02-007-0084-00	RES SMD 47.5K OHM 1% 1/10W 0805
R5003 R5024 R5026 R5103 R5124 R5126	02-007-0087-00	RES SMD 10K OHM 1/8W 0805 1%
R5203 R5224 R5226 R5309 R5316 R5330		
R5030 R5130 R5230	02-007-0088-00	RES SMD 20K OHM 1/8W 0805 1%
R5019 R5021 R5119 R5121 R5219 R5221	02-007-0091-00	RES SMD 4.7 OHM 1/4W 1206 5%
R5006 R5106 R5206	02-007-0120-00	RES SMD 3.3K OHM 5% 1/10W 0805
R5038 R5138 R5238 R5320	02-007-0126-00	RES SMD 820 OHM +/-5% 1/10W 0805
R5029 R5129 R5229	02-007-0166-00	RES SMD 330K OHM 0805 5%
R5310	02-007-0172-00	RES SMD 12K OHM 0805 5%
R5004 R5008 R5012 R5104 R5108 R5112	02-007-0177-00	RES SMD 1K OHM 0805 1%
R5204 R5208 R5212 R5308 R5317 R5305		
R5321	02-007-0227-00	RES SMD 22.1K OHM +/-1% 1/10W 0805
R5002 R5102 R5202	02-007-0236-00	RES SMD 100 OHM 1/4W 1% 1206
R5035 R5135 R5235	02-007-0258-00	RES SMD 15K OHM 1/10W 1% 0805
R5007 R5107 R5207	02-007-0314-00	RES SMD 220 OHM 5% 1/2W 2010
R5014 R5114 R5214 R5327	02-007-0318-00	RES SMD 27K OHM 5% 1/4W 1206
R5033 R5133 R5233	02-007-0323-00	RES SMD 3.3 OHM 5% 1W 2512
R5011 R5111 R5211	02-007-0324-00	RES SMD 360 OHM 5% 1/4W 1206
R5314	02-007-0325-00	RES SMD 4.22K OHM 1% 1/10W 0805
R5039 R5139 R5239	02-007-0336-00	RES SMD 75 OHM 1% 1/10W 0805
R5037 R5137 R5237 R5301	02-007-0339-00	RES SMD 1M OHM 5% 1/10W 0805
R5036 R5136 R5236 R5303	02-007-0342-00	RES SMD 22K OHM 5% 1/10W 0805
R5005 R5009 R5105 R5109 R5205 R5209	02-007-0343-00	RES SMD 22 OHM 5% 1/10W 0805
R5016 R5116 R5216	02-007-0344-00	RES SMD 2.7K OHM 5% 1/10W 0805
R5032 R5132 R5232 R5302	02-007-0347-00	RES SMD 33K OHM 5% 1/10W 0805
R5328	02-007-0348-00	RES SMD 390 OHM 5% 1/10W 0805
R5013 R5113 R5213	02-007-0353-00	RES SMD 47 OHM 5% 1/10W 0805
R5307	02-007-0356-00	RES SMD 560 OHM 5% 1/10W 0805
R5015 R5115 R5215	02-007-0358-00	RES SMD 100 OHM 5% 1/10W 0805
R5001 R5101 R5201	02-007-0438-00	RES SMD 220K OHM 5% 1/4W 1206
R5323 R5326	02-007-0440-00	RES SMD 18K OHM 5% 1/4W 1206
R5313	02-007-0468-00	RES SMD 27K OHM 0805 1%

SMD CAPACITORS

C5304 C5305 C5309	03-009-0075-00	CAP CER SMD 0.1uF 50V 20% Y5V 0603
C5005 C5008 C5105 C5108 C5205 C5208	03-009-0111-00	CAP CER SMD 100pF 50V 10% X7R 0603
C5009 C5109 C5209	03-009-0112-00	CAP CER SMD 1nF 50V 10% X7R 0603
C5006 C5106 C5206	03-009-0124-00	CAP CER SMD 10pF 50V 5% NPO 0603
C5012 C5013 C5112 C5113 C5212 C5213	03-009-0125-00	CAP CER SMD 100pF 100V 10% X7R 0805
C5302 C5315	03-009-0127-90	CAP ELEC SMD 220uF/50V ±20%
C5306 C5310 C5311	03-009-0131-00	CAP CER SMD 22nF 50V 20% Y5V 0603
C5313 C5314	03-009-0136-00	CAP ELEC SMD 10uF 16V +/-20% 4X5.4
C5303	03-009-0137-00	CAP ELEC SMD 100uF 50V +/-20% 8X10.5
C5307 C5308	03-009-0143-00	CAP ELEC SMD 47uF 50V +/-20% 6.3X7.7
C5003 C5103 C5203	03-009-0144-00	CAP ELEC SMD 470uF 16V +/-20% 10X10.5
C5004 C5104 C5204	03-009-0152-00	CAP ELEC SMD 100uF 16V +/-20% 6.3X5.4
C5301	03-009-0153-00	CAP ELEC SMD 1uF/50V ±20% B CASE 4 X 5.4
C5001 C5101 C5201	03-009-0192-00	CAP ELEC SMD 4.7uF 50V +/-20% 4X5.4

SMD DIODES

D5313-D5315	04-006-0019-00	SMD Diode RECT 1A/400V DO-214AC GS1G M4 GS1G
D5001-5006 D5101-5106 D5201-5206 D5301-5302 D5305 D5308-5311 D5316 D5317 D5318	04-006-0021-90	SMD Diode LL4148 SOD80
D5307 D5312	04-007-0026-00	SMD Zener Diode 22V 500mW 5% MMSZ5251B SOD123
D5304 D5306	04-007-0031-00	DIODE ZENER SMD 6.2V 500mW 5% SOD123 MMSZ5234B

SMD TRANSISTORS

Q5001-5003 Q5007 Q5012 Q5101-5103 Q5107 Q5112 Q5201-5203 Q5207 Q5212 Q5302	05-004-0018-90	SMD Transistor MMBT5551LT1 NPN SOT-23
Q5004 Q5104 Q5204 Q5303 Q5304	05-004-0019-90	SMD Transistor MMBT5401LT1G PNP SOT-23
Q5006 Q5106 Q5206	05-004-0030-90	XTR 2SD1918 NPN POWER 160V/1.5A 80MHz HFE 120-390 SMD CPT3
Q5005 Q5013 Q5105 Q5113 Q5205 Q5213	05-004-0031-90	XTR 2SB1275 PNP POWER 160V/1.5A 50MHz HFE 82-180 SMD CPT3
Q5301	05-004-0032-90	XTR N-CH 2SK771-5 40V 20mA IDSS=5.0 - 12.0mA SMD
Q5305	05-004-0035-90	TRANSISTOR SS PNP HFE 30 250MHz SPT DTA114EKAT146
Q5306-5308	05-004-0036-90	TRANSISTOR SS NPN HFE20 250MHz DTC123EKAT146

SURROUND POWER AMP BOARD *SEE PAGE 92 FOR SINGLE CHANNEL SERVICE KIT # 52-940-0755-90**

PCB ASSEMBLY	NSP	T755 Surround Amp Board Assembly NSP
---------------------	------------	---

RESISTORS

R5631-5632	02-001-0455-00	RES CF 2K OHM 5% 2W AXIAL
R5427-5428 R5527-5528 R5643-5646	02-005-0063-00	RES WW 0.22 OHM 5% 5W AXIAL
R5434 R5534	02-010-0014-00	RES MO 10 OHM 5% 2W AXIAL

CAPACITORS

C5410 C5411 C5510 C5511	03-002-0134-00	CAP ELEC GR 100uF 100V 20%
C5414 C5514 C5617-5620	03-004-0031-00	MPF CAP 104J/63V 5% Mini Box
C5407 C5507	03-004-0123-00	MPF CAP 0.15uF/100V/154J 5% Mini Box

DIODES

D5615-5616	04-001-0046-00	DIODE RECT 12A/600V TO-220 TYN612
D5617	04-005-0021-90	DIODE BRI 10A/400V KBK10G

TRANSISTORS

Q5411 Q5511	05-001-0100-90	TRANSISTOR PW DARLINGTON PNP 10A/150V TO-3PB 2SB1560
Q5410 Q5510	05-001-0101-90	TANSISTOR PW DARLINGTON NPN 10A/150V TO-3PB 2SD2390

VARIABLE RESISTORS

R5418 R5518	06-004-0016-90	VR SEMI-FIX RES CF 1K OHM B 30% 6mm VER
R5634	06-004-0020-90	VR SEMI-FIX RES CF 50K OHM B 30% 6mm VER

COILS

L5401 L5501	07-002-0136-90	AIR COIL 0.2uH 10% 1 X 9 X 13.5 TURNS
-------------	----------------	--

RELAY

M5601	07-005-0055-90	RELAY POWER DC12V 8A/250V 2P1T PCB MOUNT ME-11-012-2H4
-------	----------------	---

SMD ICS

U5605	01-014-0027-00	IC NJM4560M SO-8 JRC Dual Operational Amplifier
-------	----------------	--

SMD RESISTORS

R5410 R5510 R5630	02-007-0026-00	RES SMD 47K OHM 5% 1/10W 0805
R5633 R5656	02-007-0028-00	RES SMD 4.7K OHM 5% 1/10W 0805
R5417 R5517	02-007-0033-00	RES SMD 1.2K OHM 5% 1/10W 0805
R5531 R5431	02-007-0037-00	RES SMD 180K OHM 5% 1/10W 0805
R5637	02-007-0053-00	RES SMD 680K OHM 5% 1/10W 0805
R5657	02-007-0057-00	RES SMD 220 OHM 5% 1/10W 0805
R5638 R5641	02-007-0058-00	RES SMD 2.2K OHM 5% 1/10W 0805
R5403 R5424 R5426 R5503 R5524	02-007-0087-00	RES SMD 10K OHM 1/8W 0805 1%
R5526 R5659 R5642 R5652 R5635		
R5430 R5530	02-007-0088-00	RES SMD 20K OHM 1/8W 0805 1%
R5519 R5421 R5521 R5419	02-007-0091-00	RES SMD 4.7 OHM 1/4W 1206 5%
R5406 R5506	02-007-0120-00	RES SMD 3.3K OHM 5% 1/10W 0805
R5438 R5538	02-007-0126-00	RES SMD 820 OHM +/-5% 1/10W 0805
R5429 R5529	02-007-0166-00	RES SMD 330K OHM 0805 5%
R5508 R5512 R5504 R5404 R5408 R5412	02-007-0177-00	RES SMD 1K OHM 0805 1%
R5636 R5648 R5651 R5655 R5658		
R5402 R5502	02-007-0236-00	RES SMD 100 OHM 1/4W 1% 1206
R5435 R5535 R5629	02-007-0258-00	RES SMD 15K OHM 1/10W 1% 0805
R5407 R5507	02-007-0314-00	RES SMD 220 OHM 5% 1/2W 2010
R5514 R5414	02-007-0318-00	RES SMD 27K OHM 5% 1/4W 1206
R5533 R5433	02-007-0323-00	RES SMD 3.3 OHM 5% 1W 2512
R5411 R5511	02-007-0324-00	RES SMD 360 OHM 5% 1/4W 1206

R5439 R5539	02-007-0336-00	RES SMD 75 OHM 1% 1/10W 0805
R5640 R5639	02-007-0338-00	RES SMD 100K OHM 5% 1/10W 0805
R5437 R5537	02-007-0339-00	RES SMD 1M OHM 5% 1/10W 0805
R5436 R5536 R5650 R5654	02-007-0342-00	RES SMD 22K OHM 5% 1/10W 0805
R5405 R5409 R5505 R5509	02-007-0343-00	RES SMD 22 OHM 5% 1/10W 0805
R5416 R5516	02-007-0344-00	RES SMD 2.7K OHM 5% 1/10W 0805
R5432 R5532 R5627 R5628	02-007-0347-00	RES SMD 33K OHM 5% 1/10W 0805
R5413 R5513	02-007-0353-00	RES SMD 47 OHM 5% 1/10W 0805
R5415 R5515 R5649 R5653	02-007-0358-00	RES SMD 100 OHM 5% 1/10W 0805
R5401 R5501	02-007-0438-00	RES SMD 220K OHM 5% 1/4W 1206
R5647	02-007-0441-00	RES SMD 2.2M OHM 5% 1/10W 0805
SMD CAPACITORS		
C5614 C5622	03-009-0075-00	CAP CER SMD 0.1uF 50V 20% Y5V 0603
C5405 C5408 C5505 C5508	03-009-0111-00	CAP CER SMD 100pF 50V 10% X7R 0603
C5409 C5509 C5607	03-009-0112-00	CAP CER SMD 1nF 50V 10% X7R 0603
C5506 C5406	03-009-0124-00	CAP CER SMD 10pF 50V 5% NPO 0603
C5412 C5413 C5512 C5513	03-009-0125-00	CAP CER SMD 100pF 100V 10% X7R 0805
C5608 C5609 C5612	03-009-0131-00	CAP CER SMD 22nF 50V 20% Y5V 0603
C5615 C5616 C5621 C5623 C5624	03-009-0136-00	CAP ELEC SMD 10uF 16V +/-20% 4X5.4
C5403 C5503	03-009-0144-00	CAP ELEC SMD 470uF 16V +/-20% 10X10.5
C5404 C5504	03-009-0152-00	CAP ELEC SMD 100uF 16V +/-20% 6.3X5.4
C5401 C5501	03-009-0192-00	CAP ELEC SMD 4.7uF 50V +/-20% 4X5.4
C5606	03-009-0211-00	CAP ELEC SMD 220uF/16V ±20% 6.3X7.7
SMD DIODES		
D5609 D5618	04-006-0019-00	SMD Diode RECT 1A/400V DO-214AC GS1G M4 GS1G
D5401-5406 D5501-5506 D5613-5614	04-006-0021-90	SMD Diode LL4148 SOD80
D5611-5612	04-007-0033-90	DIODE ZENER SMD 12V 500mW 5% SOD123 MMSZ5242B
SMD TRANSISTORS		
Q5401-5403 Q5407 Q5412 Q5501-5503	05-004-0018-90	SMD Transistor MMBT5551LT1 NPN SOT-23
Q5507 Q5512 Q5606-5607		
Q5404 Q5504 Q5608 Q5616-5617	05-004-0019-90	SMD Transistor MMBT5401LT1G PNP SOT-23
Q5406 Q5506	05-004-0030-90	XTR 2SD1918 NPN POWER 160V/1.5A 80MHz HFE 120-390 SMD
Q5405 Q5413 Q5505 Q5513	05-004-0031-90	XTR 2SB1275 PNP POWER 160V/1.5A 50MHz HFE 82-180 SMD
Q5613 Q5615	05-004-0034-90	TRANSISTOR 2SA1037AKS PNP HFE 270-560 140MHz SMD
Q5611	05-004-0036-90	TRANSISTOR SS NPN HFE20 250MHZ DTC123EKAT146
Q5612 Q5614 Q5618	05-004-0043-90	SMD TRANSISTOR 2SC2412KS NPN HFE 270-560 180MHz SMD
DSP BOARD		
PCB ASSEMBLY*AH	50-918-0755-90	T755 AH DSP ASSY
PCB ASSEMBLY*C,CT	50-945-0755-90	T755 C/CT DSP ASSY
FIBER OPTIC		
M1004	04-004-0007-90	FIBER OPTIC TRANSMITTER 650nm 5V JST1164

M1001-1003	04-009-0004-90	FIBRE OPTIC RECEIVING UNIT 700nm JSR1164-D
INDUCTORS		
L1008-1009 L1020-1021	07-002-0132-90	IND CHOKE 10uH 10% EC36 AXIAL EC36-100K
L1007	07-002-0134-90	IND CHOKE 22uH +/-10% AXIAL EC24-220K
L6010-6011	07-002-0144-90	IND CHOKE 180uH +/-10% AXIAL EC24-181K
RELAY		
M6004	07-005-0049-90	RELAY DC12V 0.5A/125V 2P2T KH1-12VDC PCB MOUNT
TACT SWITCH		
S1001	11-007-0061-90	SW TACT 1P1T 50mA/12V VER H=5mm
RCA JACKS		
M1005-1008	15-003-0034-90	RCA JACK 1 ORANGE PCB MOUNT GOLD W/SHIELD
M6001-6003	15-003-0046-90	RCA JACK 6 W-W-W/R-R-R PCB MOUNT GOLD W/O SHIELD
SMD ICS		
U1020	01-004-0056-90	IC VOLT REG. LOW DROPOUT 3.3V 1A SOT-223 LM1117S-3.3
U1036	01-004-0061-90	IC VOLT REG LOW DROPOUT 5.0V 1A SOT-223 LM1117S-5.0
U1004	01-011-0032-90	IC FLASH MEMORY SMD 8M 3.3V SST39VF800A-70-4C-EK TSOP
U1003	01-011-0033-90	IC SDRAM 1M X 4 X 16BIT 133MHz SMD 54PIN TSOP(II) K4S641632K-T(U)C/L75
U1033	01-012-0060-00	IC LOGIC QUAD 2-INPUT MULTIPLEXER 74HC157D
U1005	01-012-0061-00	IC LOGIC 8-CHANNEL MULTIPLEXER SOP 74HC251D
U1007 U6003	01-012-0065-00	IC LOGIC 8-STAGE SHIFT-AND-STORE BUS REGISTER SMD SO16 HEF4094BT
U1018 U1019	01-012-0066-00	IC LOGIC HEX INVERTER SMD SOP 74HCU04D
U1010 U1022	01-012-0068-90	IC LOGIC OCTAL BUS TRANSCEIVER WITH 3-STATE OUTPUTS 20PIN TSSOP SN74LVC245APWR
U1011	01-012-0074-90	IC PWM CONTROL IC SOP8 TL5001CD
U1009	01-012-0083-90	IC LOGIC OCTAL BUS TRANSCEIVERS WITH 3-STATE OUTPUTS SMD SN74HCT245PWR
U1023 U1027-1031 U6004-6007 U6010 U6018 U6019	01-014-0027-00	IC NJM4560M SO-8 JRC Dual Operational Amplifier
U1017	01-020-0022-90	IC AUDIO STEREO ADC PCM1802 SOP20
U1021	01-020-0023-90	IC SUPPLY-VOLTAGE SUPERVISORY IC SOP6 TPS3103E12DBVR
U1002	01-020-0024-90	IC 192KHz DIGITAL AUDIO INTERFACE RECEIVER 28PIN SOIC CS8416 -CS
U1032*AH	01-020-0030-90	IC XMDT IC BU9450KV VQFP48C
U1001	01-027-0007-90	IC D707E001BRFP250 FLOATING-POINT DSP SMD 144 PINS RFP

U1034	01-027-0008-90	IC PCM1609A 24-BIT 192kHz 8 CH DAC SMD 48 PINS LQFP
U1035	01-027-0009-90	IC PCM1742KE 24-BIT 192kHz STEREO DAC SMD 16 PINS SSOP
U6002	01-027-0010-90	IC M61545AFP 2-CH ELECTRONIC VOLUME SMD 8 PINS SOP RENESAS
U6001	01-027-0012-90	IC R2S15205FP 8 CH ELECTRONIC VOLUME W/ INPUT SWITCH & TONE CTRL SMD 80 PINS QFP
SMD RESISTORS		
R1006 R1013 R1020 R1032 R1231 R1242-1243*AH R6004 R6016 R6101-6104 R6107-6108 R6111-6116 R6161-6162	02-007-0042-00	RES SMD 1K OHM 0603 5%
R6080 R6083	02-007-0048-00	RES SMD 68K OHM 0805 5%
R6221-6229	02-007-0089-00	RES SMD 0 OHM +/-5% 1/10W 0805
R6081 R6084	02-007-0128-00	RES SMD 150K OHM 0603 5%
R1022-1024 R1034	02-007-0134-00	RES SMD 4.7 OHM 0805 5%
R6128 R6123-6124 R6135-6140 R6145-6146 R6151-6156 R6165 R6167-6168 R6171 R6127 R6258-6261	02-007-0136-00	RES SMD 33K OHM 0603 5%
R1316 R1317 R6006-6007 R6018-6019 R6192 R6195	02-007-0139-00	RES SMD 4.7K OHM 0603 5%
R1005 R1012 R1019 R1031 R1061 R1071-1072 R6079 R6082	02-007-0140-00	RES SMD 47K OHM 0603 5%
R1062 R1069 R1240 R1244-1245*AH R1028	02-007-0141-00	RES SMD 100 OHM 0603 5%
R1226 R1272 R1190 R1199 R1208 R6262 R6263	02-007-0146-00	RES SMD 47 OHM 0603 5%
R1149 R1159 R1139 R1176 R1186 R1196 R1205 R1206 R1223 R1224 R1230 R1236-1237 R1098 R1259-1264 R1267-1268 R1270-1271 R1107 R1114 R1123 R1129 R1066 R1254*AH R1298 R1301 R6085-6087 R6174-R6179 R6182-6185 R1191 R1200 R1188 R1192 R1197 R1201 R1096 R1105 R1112 R1121 R1127 R1136 R1146 R1156 R1173 R1183	02-007-0151-00	RES SMD 10 OHM 0603 5%
R1249*AH R1250-1253*AH R6010-6011 R6022-6023 R1249 R6073	02-007-0157-00	RES SMD 10K OHM 0603 1%
R6017 R6013 R6005 R6001 R6188	02-007-0267-00	RES SMD 100K OHM 5% 1/16W 0603
R6105-6106 R6109-6110 R6117-6118	02-007-0268-00	RES SMD 56K OHM 5% 1/16W 0603
R1001 R1008 R1015 R1232	02-007-0270-00	RES SMD 330 OHM 1% 1/16W 0603
R1246-1247*AH R1300 R1256*AH R1318 R1319 R1324 R1325*AH R6142 R6144 R6148 R6150 R6158 R6160 R6264 R6265	02-007-0288-00	RES SMD 0 OHM 5% 1/16W 0603
R1239	02-007-0291-00	RES SMD 150 OHM 5% 1/16W 0603
R1025-1027 R1047 R1007 R1014 R1021 R1320 R1321 R6231 R6232 R6233	02-007-0292-00	RES SMD 2.2K OHM 1% 1/16W 0603
R1037-1041 R1265-1266	02-007-0293-00	RES SMD 33 OHM 5% 1/16W 0603
R6008-6009 R6020-6021	02-007-0294-00	RES SMD 470 OHM 5% 1/16W 0603
R1095 R1104 R1111 R1120 R1126 R1135 R1145 R1155 R1172 R1182	02-007-0296-00	RES SMD 4.99K OHM +/-1% 1/16W 0603
R1073 R6235-6236	02-007-0300-00	RES SMD 200K OHM +/-5% 1/16W 0603

R1045 R1187 R1099 R1108 R1140 R1150	02-007-0301-00	RES SMD 620 OHM +/-5% 1/16W 0603
R1160 R1115 R1241 R1177 R1130		
R6186 R6189	02-007-0306-00	RES SMD 1K OHM 1% 1/16W 0603
R1050 R6166 R6169-6170	02-007-0312-00	RES SMD 20K OHM 1/16W 1% 0603
R6074	02-007-0319-00	RES SMD 300 OHM 5% 1/16W 0603
R6003 R6015 R6187	02-007-0321-00	RES SMD 3.3K OHM 1% 1/16W 0603
R6163-6164	02-007-0335-00	RES SMD 75K OHM 1% 1/16W 0603
R1049	02-007-0337-00	RES SMD 91K OHM 1% 1/16W 0603
R1002 R1009 R1016 R1029	02-007-0341-00	RES SMD 120 OHM 5% 1/16W 0603
R1042-R1044 R1046		
R1068	02-007-0345-00	RES SMD 3K OHM 5% 1/16W 0603
R1074	02-007-0350-00	RES SMD 39K OHM 5% 1/16W 0603
R1003 R1010 R1017 R1030	02-007-0351-00	RES SMD 39 OHM 5% 1/16W 0603
R1011 R1018 R1004	02-007-0357-00	RES SMD 75 OHM 5% 1/16W 0603
R6012 R6024	02-007-0372-00	RES SMD 220 OHM 5% 1/16W 0603
R6191	02-007-0383-00	RES SMD 2.7K OHM +/-1% 1/16W 0603
R6002 R6014	02-007-0386-00	RES SMD 620 OHM 1% 1/16W 0603
R1093 R1102 R1109 R1118 R1124	02-007-0533-90	RES SMD 2.49K OHM 1% 1/16W 0603
R1133 R1143 R1153 R1170 R1180		

SMD CAPACITORS

C1015 C1017 C1019 C1007 C1023	03-009-0075-00	CAP CER SMD 0.1uF 50V 20% Y5V 0603
C1025 C1028 C1030 C1032 C1035-1037		
C1011 C1003 C1047 C1049 C1051 C1053		
C1056 C1062 C1064 C1067-1068 C1070		
C1077 C1079-1124 C1126 C1128-1131		
C1133 C1134 C1136 C1013 C1288 C1293		
C1296 C1303-1305*AH C1310 C1311*AH		
C1313 C1315-1322*AH C1327 C1330		
C1332 C1334 C1341 C6097 C6101 C6103		
C6139 C6141 C6217-6218 C6221-6222		
C6225-6226 C6229-6230 C6233-6234		
C6237-6238 C6241-6242		
C1297	03-009-0076-00	CAP CER SMD 27pF/50V +10% NPO 0603
C1175 C1182 C1189 C1196 C1203	03-009-0104-00	CAP CER SMD 2700pF 50V 5% X7R 0603
C1210 C1217 C1224 C1249 C1259		
C1042 C1230-1231 C1233-1234 C1236	03-009-0111-00	CAP CER SMD 100pF 50V 10% X7R 0603
C1238 C1241 C1300-1302 C6001-6018		
C6124 C6127 C6130-6132 C6135 C6262		
C1044 C1063 C1065	03-009-0112-00	CAP CER SMD 1nF 50V 10% X7R 0603
C1001 C1004-1005 C1008-1009 C1012	03-009-0113-00	CAP CER SMD 10nF 50V 10% X7R 0603
C1022 C1038 C1043 C6082-6083 C6085		
C1002 C1006 C1010 C1177 C1184 C1191	03-009-0114-00	CAP CER SMD 220pF 50V 10% X7R 0603
C1198 C1205 C1212 C1219 C1226 C1251		
C1261 C6195 C6147 C6150 C6155 C6158		
C1039	03-009-0117-00	CAP CER SMD 330pF 50V 10% X7R 0603
C1058	03-009-0128-00	CAP CER SMD 1200pF 50V 10% X7R 0603
C1048 C1054 C1050	03-009-0128-90	CAP ELEC SMD 470uF/10V ±20%
C1021	03-009-0130-00	CAP CER SMD 22pF 50V 5% COG 0603
C1045,C6096 C6100	03-009-0131-00	CAP CER SMD 22nF 50V 20% Y5V 0603
C1066	03-009-0133-00	CAP CER SMD 470pF 50V 5% NPO 0603
C6095 C6099	03-009-0134-00	CAP CER SMD 0.047uF 50V 10% X7R 0603

C1014 C1016 C1018 C1020 C1024 C1031 C1033-1034 C1046 C1052 C1069 C1071 C1076 C1078 C1173 C1180 C1187 C1194 C1201 C1208 C1215 C1222 C1247 C1257 C1264 C1269 C1294-1295 C1312 C1326 C1328 C1329 C1331 C1333 C1340 C1335 C6200-6201 C6243-6244 C1055 C6261	03-009-0136-00	CAP ELEC SMD 10uF 16V +/-20% 4X5.4
C1265 C1270 C1342 C6021-6022 C6065-6066 C6069-6074 C6081 C6084 C6122-6123 C6136 C6019 C6153 C6020 C6161	03-009-0138-00	CAP ELEC SMD 1000uF 10V +/-20% 10X10.5
C1265 C1270 C1342 C6021-6022 C6065-6066 C6069-6074 C6081 C6084 C6122-6123 C6136 C6019 C6153 C6020 C6161	03-009-0140-00	CAP ELEC SMD 22uF 16V +/-20% 5X5.4
C1179 C1186 C1193 C1200 C1207 C1214 C1221 C1228 C1253 C1263	03-009-0142-00	CAP ELEC SMD 3.3uF 50V +/-20% 4X5.4
C1029 C1137-1141 C1144 C1146-C1150 C1152 C1323*AH C6087-6093 C6102 C6137 C6140 C6086 C6219-6220 C6223-6224 C6227-6228 C6231-6232 C6235-6236 C6239-6240 C6245 C6077-6080	03-009-0143-00	CAP ELEC SMD 47uF 50V +/-20% 6.3X7.7
C1287	03-009-0152-00	CAP ELEC SMD 100uF 16V +/-20% 6.3X5.4
C1287	03-009-0153-00	CAP ELEC SMD 1uF/50V ±20% B CASE 4 X 5.4
C6098 C6094	03-009-0198-00	CAP CER SMD 0.15uF 25V 10% X7R 0603
C1268 C1273	03-009-0211-00	CAP ELEC SMD 220uF/16V ±20% 6.3X7.7
C6146 C6154	03-009-0244-90	CAP ELEC SMD 10uF 16V +/-20% 5x5.4 BI-POLAR
C6149 C6157	03-009-0245-90	CAP ELEC SMD 22uF 16V +/-20% 6.3x5.4 BI-POLAR
SMD DIODES		
D6001-6004 D6011	04-006-0019-00	DIODE RECT 1A/400V DO-214AC SMD GS1G M4 GS1G
D1002 D1003 D6012 D6013	04-006-0021-90	SMD Diode LL4148 SOD80
D6007-6010	04-007-0039-90	DIODE ZENER SMD 12V 500mW 5% SOD123 MM1Z12
D6005-6006	04-007-0042-90	DIODE ZENER SMD 7.5V 500mW 5% SOD123 MMSZ5236B
SMD TRANSISTORS		
Q1016 2SA1952TLQ	05-001-0096-90	XTR PW PNP 5A/60V SC-63
Q1020-1022 Q6005-6008 Q6021-6022	05-004-0017-00	TRANSISTOR SS NPN SMD SOT-23 2SC4695
Q6101	05-004-0030-90	XTR 2SD1918 NPN POWER 160V/1.5A 80MHz HFE 120-390 SMD
Q6102	05-004-0031-90	XTR 2SB1275 PNP POWER 160V/1.5A 50MHz HFE 82-180 SMD
Q1024 Q1030 Q1032 Q1033 Q6106	05-004-0035-90	TRANSISTOR SS NPN HFE30 250MHZ SPT DTC114EKAT146
Q6103	05-004-0036-90	TRANSISTOR SS NPN HFE20 250MHZ DTC123EKAT146
Q1025 Q1031 Q1034 Q1035 Q6017 Q6020 Q6104 Q6105	05-004-0037-90	TRANSISTOR SS PNP HFE 30 250MHZ SPT DTA114EKAT146

SMD INDUCTORS

L1018*AH	07-007-0017-90	IND 2.7uH SMD 10% 0805 CI201209-2R7KG
L1001-1004	10-009-0005-90	DIGITAL AUDIO INTERFACE SIGNAL TRANSFORMER ER9.5 225uH
X1001C	14-004-0020-90	CRYSTAL OSCILLATOR 24.576MHz 3.3V 50ppm 30pF SMD
X1003*AH	14-004-0024-90	CRYSTAL OSCILLATOR 45.1584MHz 3.3V 50ppm 30pF SMD

KEYBOARD**PCB ASSEMBLY****50-922-0755-90****T755 KEYBOARD ASSY****CAPACITORS**

C2208	03-002-0137-00	CAP ELEC SS 1uF 50V 20% 85C
C2211	03-002-0143-00	CAP ELEC SS 47uF 16V 20% 85C

IR

D2202	04-009-0003-90	IR RX 37.9kHz SHIELD RT FM-6038TM2-5AN
-------	----------------	---

ENCODER

M2201	06-006-0009-90	ENCODER ROTATRY STD L=20MM VERT W/O CLICK
-------	----------------	--

TACT SWITCHES

S2201-S2218	11-007-0061-90	SW TACT 1P1T 50mA/12V VER
-------------	----------------	---------------------------

VFD

VD2201	12-005-0029-90	VFD 16-BT-130-GINK
--------	----------------	--------------------

LED

D2201	12-006-0125-90	LED RED-ORN-BLU CIRCULAR 5X8.7MM BL-BUBJFB52C4V-1 COMMON CATHODE
-------	----------------	--

SMD IC

U2201	01-012-0065-00	IC LOGIC 8-STAGE SHIFT-AND-STORE BUS REGISTER SMD SO16 HEF4094BT
-------	----------------	---

SMD RESISTORS

R2201 R2237-R2239	02-007-0042-00	RES SMD 1K OHM 0603 5%
R2204	02-007-0136-00	RES SMD 33K OHM 0603 5%
R2202	02-007-0139-00	RES SMD 4.7K OHM 0603 5%
R2232-2233	02-007-0141-00	RES SMD 100 OHM 0603 5%
R2210	02-007-0151-00	RES SMD 10 OHM 0603 5%
R2207 R2212-2216 R2230-2231	02-007-0157-00	RES SMD 10K OHM 0603 1%
R2203 R2211 R2234-2236 R2240 R2241	02-007-0292-00	RES SMD 2.2K OHM 1% 1/16W 0603
R2205 R2209	02-007-0294-00	RES SMD 470 OHM 5% 1/16W 0603
R2206 R2208	02-007-0315-00	RES SMD 22 OHM 5% 1/4W 1206

SMD CAPACITORS

C2201-2204 C2207 C2210	03-009-0075-00	CAP CER SMD 0.1uF 50V 20% Y5V 0603
C2205-2206	03-009-0111-00	CAP CER SMD 100pF 50V 10% X7R 0603
C2212	03-009-0119-00	CAP CER SMD 4.7nF 50V 10% X7R 0603

SMD DIODES		
D2204-2209	04-006-0021-90	SMD Diode LL4148 SOD80
D2203	04-007-0031-00	DIODE ZENER SMD 6.2V 500mW 5% SOD123 MMSZ5234B
SMD TRANSISTORS		
Q2201	05-004-0030-90	XTR 2SD1918 NPN POWER 160V/1.5A 80MHz HFE 120-390 SMD
Q2202-Q2204 Q2205 Q2206	05-004-0037-90	TRANSISTOR SS PNP HFE30 250MHz SPT DTA114EKAT146
JUMPERS		
JMP1 JMP3 JMP5-12 JMP16 JMP20-23 JMP26-29 JMP32-34 JMP36 JMP38 JMP43	17-016-0077-00	Jumper wire Dia. 0.5mm L=52.0mm
JMP2 JMP4 JMP13-15 JMP17-19 JMP24-25 JMP30-31 JMP35 JMP37 JMP39-41	17-016-0080-90	Jumper Wire Dia. 0.5mm For L Smaller than 14mm
SPEAKER BOARD		
PCB ASSEMBLY	50-927-0755-90	T755 SPEAKER ASSY
SPEAKER TERMINALS		
M8101	16-001-0429-90	SPEAKER TERMINAL 6P BINDING R/B W/O PLUG KF-J5000-06
M5101 M5102	16-001-0430-90	SPEAKER TERMINAL 4P BINDING R/B W/O PLUG KF-J5000-04
TRIGGER BOARD		
PCB ASSEMBLY*AH	50-930-0755-90	T755 AH TRIGGER ASSY
PCB ASSEMBLY*C,CT	50-947-0755-90	T755 C/CT TRIGGER ASSY
CAPACITORS		
C2309*C,CT C2314 C2316 C2325 C2328 C2329	03-002-0129-00	CAP ELEC SS 10uF 16V 20% 85C
C2318-2320 C2324	03-002-0137-00	CAP ELEC SS 1uF 50V 20% 85C
C2311*C,CT	03-002-0143-00	CAP ELEC SS 47uF 16V 20% 85C
SLIDE SWITCHES		
S2301-2302	11-002-0042-90	SW SLIDE 2P2T RIGHT L=9
JACKS		
M2301-M2304	15-002-0030-90	PHONE JACK X2 BLACK PCB MOUNT 3.5mm RIGHT ANGLE
XM CONNECTOR		
M2307*AH	16-001-0440-90	XM 4 PINS SMALL CONNECTOR B 2.4mm PCB MOUNT
DAB CONNECTOR		
M2306*C,CT	15-017-0003-90	DIN MINI JACK BLACK PCB MOUNT W/ COVER RIGHT ANGLE 9 PINS
RS232 CONNECTOR		
M2305	16-002-0200-90	DB9 FEMALE CONNECTOR PCB MOUNT RIGHT ANGLE

SMD ICs

U2304*C,CT	01-004-0056-90	IC VOLT REG. LOW DROPOUT 3.3V 1A SOT-223 LM1117S-3.3
U2303	01-012-0075-90	IC 74HC86D LOGIC QUAD 2-INPUT EXCLUSIVE-OR GATE SMD 14 PINS SOIC
D2308*AH	01-012-0076-90	IC CM1213 8-Channel Low Capacitance ESD Protection Arrays CM1213-08MR
U2301	01-015-0005-90	IC RS-232 DRIVERS AND RECEIVERS ST232BDR
U2302	01-028-0003-90	IC TPS2011A 8-SOIC LEAD FREE

SMD RESISTORS

R2330*C,CT	02-007-0042-00	RES SMD1K OHM 0603 5%
R2341	02-007-0127-00	RES SMD 15K OHM 0603 5%
R2309	02-007-0136-00	RES SMD 33K OHM 0603 5%
R2329 R2348*C,CT	02-007-0139-00	RES SMD 4.7K OHM 0603 5%
R2320-2321	02-007-0146-00	RES SMD 47 OHM 0603 5%
R2324	02-007-0149-00	RES SMD 1.8K OHM 0603 5%
R2304 R2308 R2313 R2316 R2319	02-007-0157-00	RES SMD 10K OHM 0603 1%
R2322-2323 R2344-2346 R2351		
R2310	02-007-0267-00	RES SMD 100K OHM 5% 1/16W 0603
R2331-2332*AH R2339	02-007-0288-00	RES SMD 0 OHM 5% 1/16W 0603
R2303	02-007-0292-00	RES SMD 2.2K OHM 1% 1/16W 0603
R2311-2312 R2314-2315 R2317-2318	02-007-0323-00	RES SMD 3.3 OHM 5% 1W 2512
R2354	02-007-0343-00	RES SMD 22 OHM 5% 1/10W 0805
R2305-2307	02-007-0356-00	RES SMD 560 OHM 5% 1/10W 0805
R2358 R2359	02-007-0396-00	RES SMD 100 OHM +/-5% 1W 2512

SMD CAPACITORS

C2305-2308 C2310*C,CT	03-009-0075-00	CAP CER SMD 0.1uF 50V 20% Y5V 0603
C2315 C2326 C2327		
C2302-2304	03-009-0078-00	CAP CER SMD 47pF/50V 10% NPO 0603
C2331*AH	03-009-0100-00	CAP CER SMD 0.22uF 50V 5% X7R 1206
C2317	03-009-0111-00	CAP CER SMD 100pF 50V 10% X7R 0603
C2301	03-009-0113-00	CAP CER SMD 10nF 50V 10% X7R 0603

SMD DIODES

D2301-2306 D2307*C,CT	04-006-0021-90	SMD Diode LL4148 SOD80
-----------------------	----------------	------------------------

SMD TRANSISTORS

Q2311 Q2313 Q2309	05-004-0031-90	XTR 2SB1275 PNP POWER 160V/1.5A 50MHz HFE 82-180 SMD
Q2301 Q2303 Q2305 Q2307-2308 Q2310	05-004-0035-90	TRANSISTOR SS NPN HFE30 250MHz SPT DTC114EKAT146
Q2312 Q2314 Q2316-2319*C,CT Q2321		
Q2302 Q2304 Q2306 Q2320	05-004-0037-90	TRANSISTOR SS PNP HFE 30 250MHz SPT DTA114EKAT146

JUMPERS

JMP1 JMP3 JMP4 JMP19 JMP28	17-016-0077-00	Jumper wire Dia. 0.5mm L=52.0mm
JMP2 JMP5-JMP18 JMP20	17-016-0080-90	Jumper Wire Dia. 0.5mm For L Smaller than 14mm
JMP21 JMP23-JMP26		

COMPONENT VIDEO BOARD**PCB ASSEMBLY****50-932-0755-90****T755 COMPONENT VIDEO ASSY****INDUCTORS**

L4502-4503

07-002-0135-90

IND CHOKE 5.6uH +/-10% AXIAL
EC24-5R6K**CRYSTAL**

X4501

14-002-0025-90

CRYSTAL 14.31818MHz 30ppm 16pF
HC-49S 01-CR1-02-14M318-16**JACKS**

M4001-4004

15-003-0025-90

RCA JACK 3 G-BL-R PCB MOUNT GOLD
(W COVER)**SMD ICS**

U4504

01-004-0056-90

IC VOLT REG LOW DROPOUT 3.3V 1A
SOT-223 LM1117S-3.3

U4505

01-004-0057-90

IC VOLT REG. LM1117S-1.8 LOW
DROPOUT 1.8V 1A SOT-223

U4520

01-010-0031-90

IC MCU 8 BITS 2K ROM 128 BYTES
RAM SOIC 20 PINS ATtiny261-20SU

U4002-4003

01-012-0067-00

IC Logic Analog Multiplexer/Demultiplexer
SMD SOIC-16 74HC4052D

U4518

01-012-0068-90

IC LOGIC OCTAL BUS TRANSCEIVER
WITH 3-STATE OUTPUTS 20PIN TSSOP
SN74LVC245APWR

U4513

01-012-0077-90

IC PCA9517 LEVEL TRANSLATING 12C-
BUS REPEATER PCA9517D SMD SO8

U4517

01-012-0082-90

IC LOGIC OCTAL BUFFERS/DRIVERS
WITH 3-STATE OUTPUTS 20PIN TSSOP
SN74AHCT244PWR

U4001 U4501 U4511

01-026-0001-90

IC Video 3-Channel 75 OHM Driver Ssop
BA7660FS

U4514

01-026-0007-90

IC MC141585DW LCD MONITOR OSD
II-16 SMD 16 PINS SOIC

U4507

01-029-0001-90

IC NTSC/PAL/SECAM 4X10BIT VIDEO
DECODER W/MACR YCBCR/RGB
INPUTS 80PIN PQFP TVP5146PFP

U4508

01-029-0002-90

IC SAA7128AH DIGITAL VIDEO
ENCODER QFP44**SMD RESISTORS**

R4597

02-007-0146-00

RES SMD 47 OHM 0603 5%

R4535

02-007-0271-00

RES SMD 1M OHM 5% 1/16W 0603

R4505-4507 R4529-4531 R4563

02-007-0288-00

RES SMD 0 OHM 5% 1/16W 0603

R4594-4596 R4601 R4613-4615 R4626

R4621

02-007-0289-00

RES SMD 68 OHM +/-1% 1/16W 0603

R4551-4554 R4627-4628

02-007-0292-00

RES SMD 2.2K OHM 1% 1/16W 0603

R4564 R4634

02-007-0306-00

RES SMD 1K OHM 1% 1/16W 0603

R4592

02-007-0319-00

RES SMD 300 OHM 5% 1/16W 0603

R4624

02-007-0341-00

RES SMD 120 OHM 5% 1/16W 0603

R4004-4006 R4555-4557 R4581-4583

02-007-0352-00

RES SMD 470K OHM 5% 1/16W 0603

R4001-4003 R4011-4019 R4520-4528

02-007-0357-00

RES SMD 75 OHM 5% 1/16W 0603

R4547-4549 R4558-4560 R4585-4587

R4591 R4593 R4598 R4599 R4623

R4501 R4502

02-007-0367-00

RES SMD 0 OHM 5% 1/10W 0805

R4589

02-007-0369-00

RES SMD 390 OHM 5% 1/16W 0603

R4609-4610	02-007-0372-00	RES SMD 220 OHM 5% 1/16W 0603
R4588 R4590	02-007-0393-00	RES SMD 270 OHM 5% 1/16W 0603
R4622	02-007-0434-00	RES SMD 56 OHM 5% 1/16W 0603
R4536 R4633	02-007-0435-00	RES SMD 10K OHM +/-5% 1/16W 0603
R4509-4510	02-007-0436-00	RES SMD 12 OHM +/-5% 1/16W 0603
SMD CAPACITORS		
C4545-4551 C4621 C4623	03-009-0049-00	CAP ELEC SMD 100uF/16V ±20% 6.3X5.5
C4001 C4009-4010 C4501-4531 C4533-4534 C4537 C4539-4540 C4634 C4646-4657 C4674 C4603-4614 C4658-4660	03-009-0075-00	CAP CER SMD 0.1uF/50V 20% Y5V 0603
C4572-4573	03-009-0130-00	CAP CER SMD 22pF 50V 5% COG 0603
C4556 C4636	03-009-0136-00	CAP ELEC SMD 10uF 16V +/-20% 4 x5.4
C4003-4005	03-009-0138-00	CAP ELEC SMD 1000uF 10V +/-20% 10x10.5
C4011-4019 C4562	03-009-0141-00	CAP ELEC SMD 2.2uF 50V +/-20% 4x5.4
C4002 C4020-4021	03-009-0143-00	CAP ELEC SMD 47uF 50V +/-20% 6.3x7.7
C4006-4008 C4558-4560 C4627-4629	03-009-0153-00	CAP ELEC SMD 1uF/50V ±20% B CASE 4 X 5.4
C4577-4578 C4581-4585 C4600-4602	03-009-0157-00	CAP CER SMD 560pF 50V 10% X7R 0603
C4615-4620	03-009-0164-00	CAP CER SMD 680pF 50V 10% X7R 0603
SMD DIODES		
D4501-4502	04-006-0019-00	SMD Diode RECT 1A/400V DO-214AC GS1G M4 GS1G
SMD TRANSISTOR		
Q4507	05-004-0034-90	TRANSISTOR 2SA1037AKS PNP HFE 270-560 140MHz SMD
SMD INDUCTORS		
L4501 L4504 L4506 L4511-4525	07-007-0017-90	IND 2.7uF SMD 10% 0805 CI201209-2R7KG
SMD OSCILLATOR		
X4503	14-004-0030-90	CRYSTAL OSCILLATOR 13.5000MHZ 3.3V 50ppm 30pF SMD
HDMI BOARD		
PCB ASSEMBLY	50-933-0755-90	T755 HDMI ASSY
INDUCTOR		
L4301	07-002-0132-90	IND CHOKE 10uH 10% EC36 AXIAL EC36-100K
JACK		
J4305	15-002-0035-90	PHONE JACK 1 GREEN PCB MOUNT 3.5mm RIGHT
SMD ICS		
U4303	01-004-0056-90	IC VOLT REG. LOW DROPOUT 3.3V 1A SOT-223 LM1117S-3.3

D4301-4304	01-012-0076-90	IC CM1213 8-Channel Low Capacitance ESD Protection Arrays CM1213-08MR
U4301	01-028-0002-90	IC TMDS341PFC 3-TO-1 DVI/HDMI SWITCH SMD 80 PINS PQFP
SMD RESISTORS		
R4640	02-007-0055-00	RES SMD 750 OHM 0805 5%
R4305 R4307 R4308	02-007-0288-00	RES SMD 0 OHM 5% 1/16W 0603
R4301	02-007-0326-00	RES SMD 4.64K OHM 1% 1/10W 0805
R4302-4304	02-007-0340-00	RES SMD 1 OHM 5% 1/10W 0805
R4641	02-007-0430-00	RES SMD 1.5K OHM 1% 1/10W 0805
SMD CAPACITORS		
C4301-4304 C4310 C4313-4317	03-009-0075-00	CAP CER SMD 0.1uF 50V 20% Y5V 0603
C4318-4329	03-009-0113-00	CAP CER SMD 10nF 50V 10% X7R 0603
C4311-4312	03-009-0128-90	CAP ELEC SMD 470uF/10V ±20%
FRONT INPUT BOARD		
PCB ASSEMBLY	50-948-0755-90	T755 FRONT INPUT ASSY
CAPACITORS		
C9309 C9307 C9315 C9320-9321	03-002-0073-00	CAP ELEC GS 22uF 16V 20% 85C
C9302-9305 C9314	03-002-0157-00	CAP ELEC SS 2.2uF 50V 20% 85C
FIBER OPTIC		
M9301	04-009-0004-90	FIBRE OPTIC RECEIVING UNIT 700nm JSR1164-D
JACKS		
M9302	15-002-0028-90	PHONE JACK 1 BLACK PCB MOUNT 3.5mm RIGHT
M9308	15-002-0029-90	PHONE JACK D6.3 1 PCB MOUNT GOLD
M9305	15-003-0048-90	RCA JACK 1 YELLOW PCB MOUNT GOLD RCA-105BL1-13Z1 (W/O COVER)
M9306	15-003-0049-90	RCA JACK 1 RED PCB MOUNT GOLD RCA-105AL1-14Z1 (W/O COVER)
M9307	15-003-0050-90	RCA JACK 1 WHITE PCB MOUNT GOLD RCA-105AL1-12Z1 (W/O COVER)
M9304	15-017-0001-90	DIN JACK 1 BLACK PCB MOUNT MD-113
SMD IC		
U9301	01-014-0027-00	IC NJM4560M SO-8 JRC Dual Operational Amplifier
SMD RESISTORS		
R9333	02-007-0042-00	RES SMD 1K OHM 0603 5%
R9301	02-007-0134-00	RES SMD 4.7 OHM 0805 5%
R9307 R9310 R9311 R9330-9331 R9332	02-007-0136-00	RES SMD 33K OHM 0603 5%
R9320 R9323 R9327	02-007-0139-00	RES SMD 4.7K OHM 0603 5%
R9313	02-007-0143-00	RES SMD 18K OHM 0603 5%
R9319 R9326	02-007-0157-00	RES SMD 10K OHM 0603 1%
R9317	02-007-0160-00	RES SMD 43K OHM 0603 5%
R9337	02-007-0177-00	RES SMD 1K OHM 0805 1%
R9325 R9324	02-007-0267-00	RES SMD 100K OHM 5% 1/16W 0603
R9305 R9308 R9328-9329	02-007-0288-00	RES SMD 0 OHM 5% 1/16W 0603

R9314 R9316	02-007-0292-00	RES SMD 2.2K OHM 1% 1/16W 0603
R9321-9322	02-007-0294-00	RES SMD 470 OHM 5% 1/16W 0603
R9318	02-007-0319-00	RES SMD 300 OHM 5% 1/16W 0603
R9302-9304	02-007-0357-00	RES SMD 75 OHM 5% 1/16W 0603
SMD CAPACITORS		
C9301 C9316-9317 C9323-9324	03-009-0075-00	CAP CER SMD 0.1uF 50V 20% Y5V 0603
C9306 C9308 C9318-9319	03-009-0111-00	CAP CER SMD 100pF 50V 10% X7R 0603
C9313	03-009-0114-00	CAP CER SMD 220pF 50V 10% X7R 0603
C9322	03-009-0116-00	CAP CER SMD 33pF 50V 10% X7R 0603
C9325	03-009-0127-00	CAP CER SMD 1uF 16V +80/-20% Y5V 0805
SMD DIODE		
D9301	04-007-0041-90	DIODE ZENER SMD 5.1V 500mW 5% SOD123
SMD TRANSISTORS		
Q9303-9305	05-004-0017-00	TRANSISTOR SS NPN SMD SOT-23 2SC4695
Q9301-9302	05-004-0037-90	TRANSISTOR SS PNP HFE 30 250MHz SPT DTA114EKAT146
JUMPERS		
JMP3 JMP4 JMP6 JMP10 JMP11 JMP17	17-016-0077-00	Jumper wire Dia. 0.5mm L=52.0mm
JMP1 JMP2 JMP5 JMP7-JMP9	17-016-0080-90	Jumper Wire Dia. 0.5mm For L Smaller than 14mm
JMP12-JMP16 JMP18 JMP19		
JMP21 JMP22 JMP25		
CONNECTOR #1 BOARD		
PCB ASSEMBLY	50-938-0755-90	T755 CONNECTION ASSY

IC BLOCK DIAGRAM

MAINBOARD

LM1117 / LM1117S

(U2008 in Mainboard, U1020, U1036 in DSP, U4303 in HDMI, U4504, U4505 in Component)

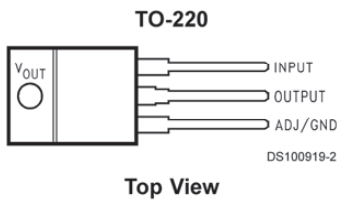
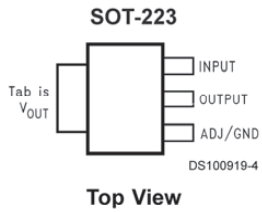

AME8530

(U2006)

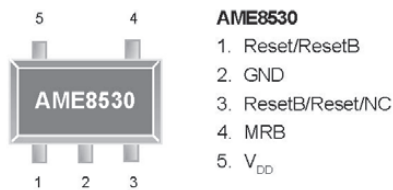

M30280

(U2001)

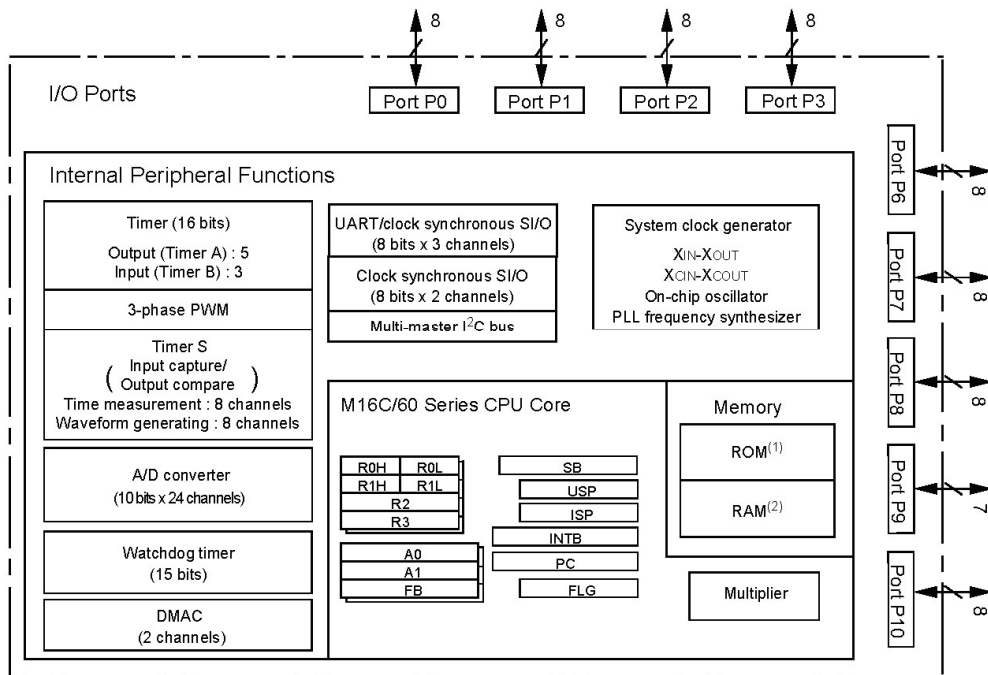

ATMEGA48-20
(U2007)

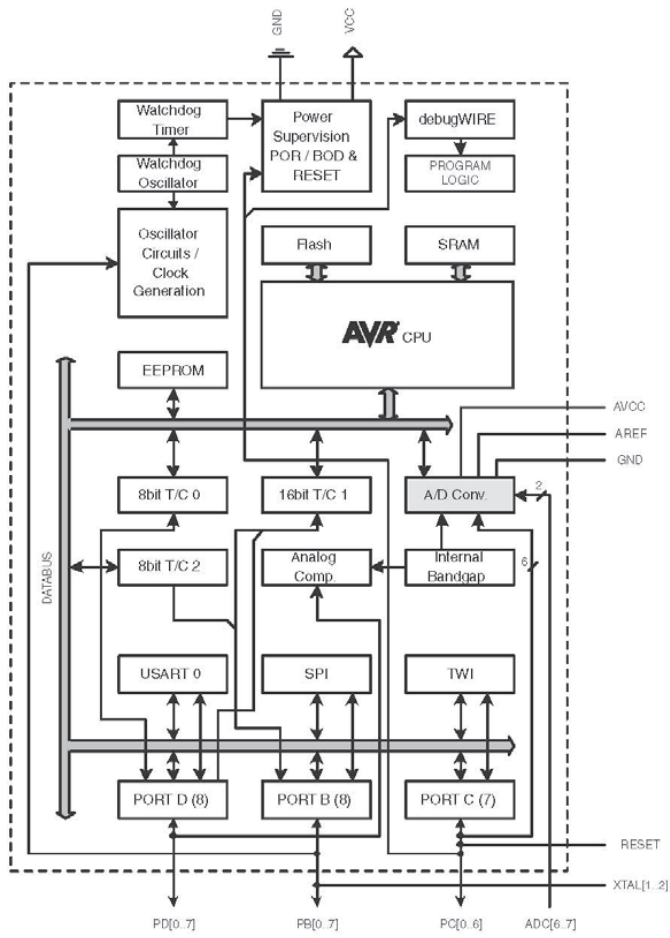

AT24C16
(U2002)

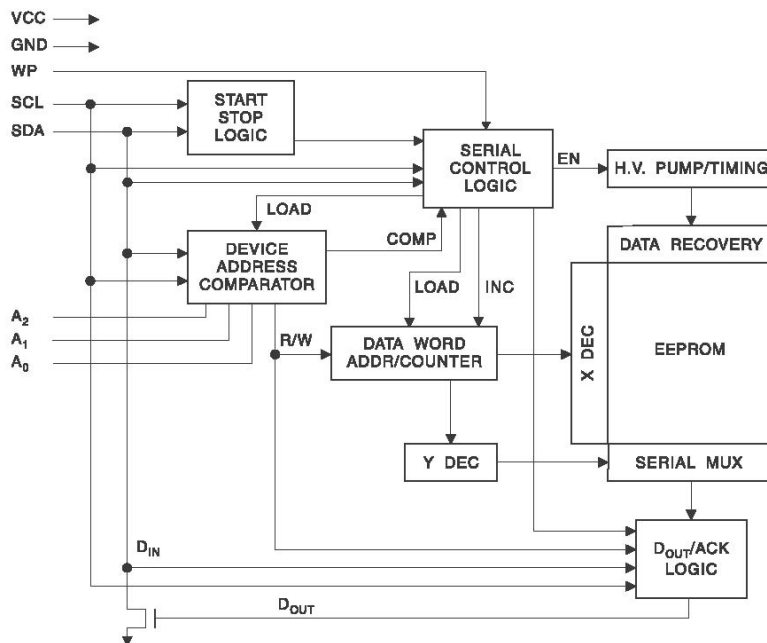

74HC00D
(U2009)

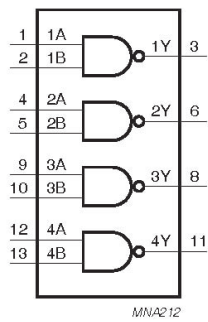

HEF4094BT
(U2003, U4103-4106, U6901 in Mainboard, U1007, U6003 in DSP, U2201 in Keyboard)

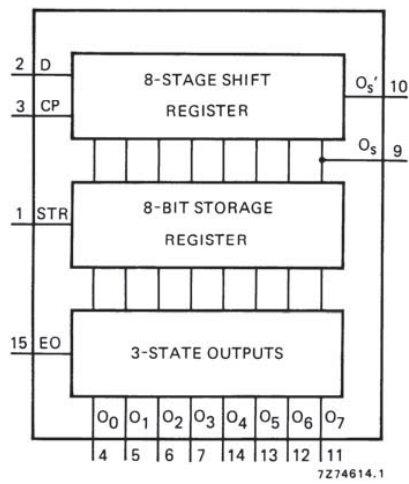

74HC132
(U2005)

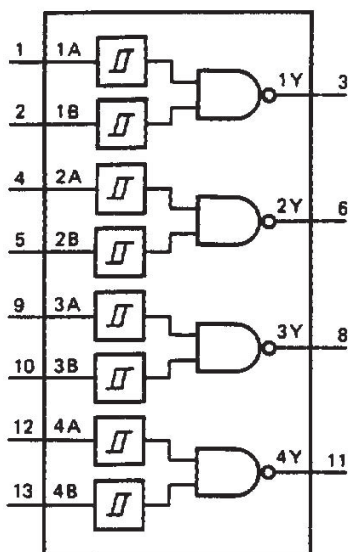

NJM4560M

(U6501, U6601, U6701, U6801 in Mainboard, U1023, U1027-1031, U6004-6007, U6010, U6018, U6019 in DSP, U5605 in AMP-S, U9301 in F-Input)

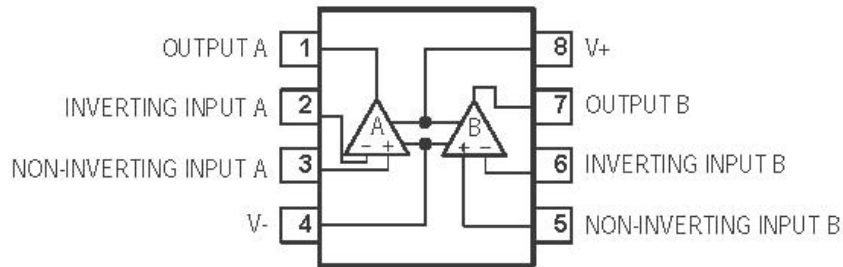

BA7660FS

(U4101-4102 in Mainboard, U4001, U4501, U4511 in Component)

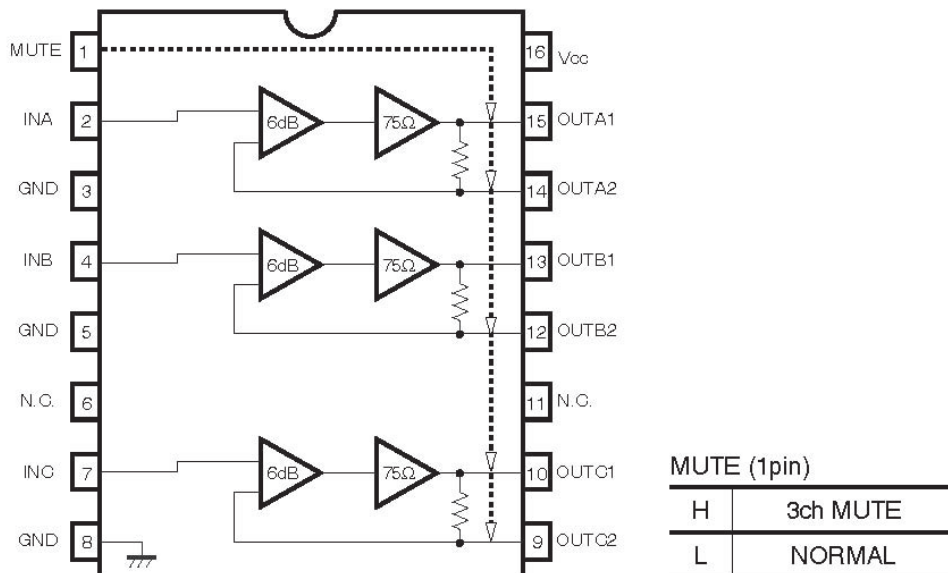

DSP

D707E0001BRFP250

(U1001)

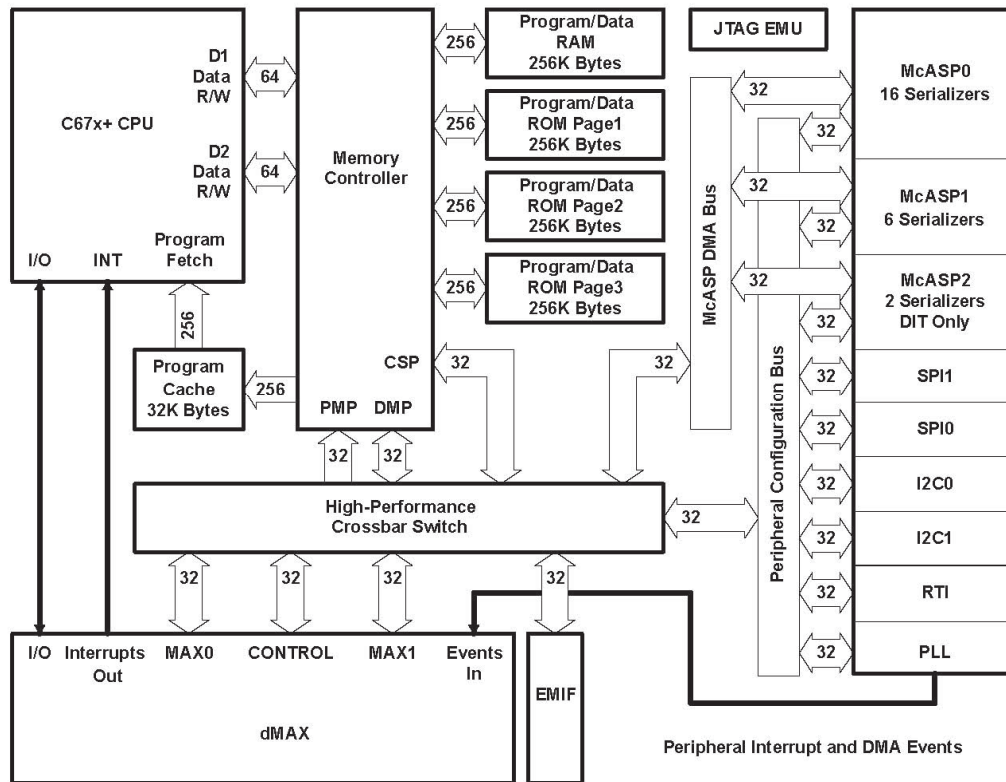

PCM1609A

(U1034)

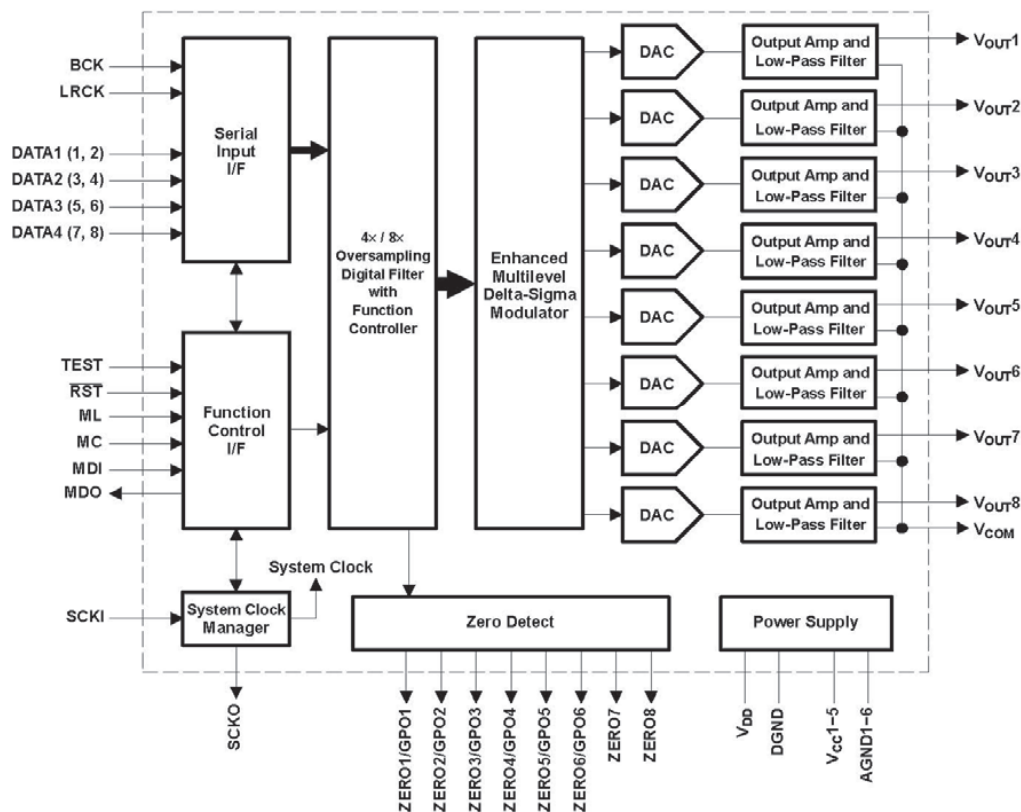

PCM1742KE
(U1035)

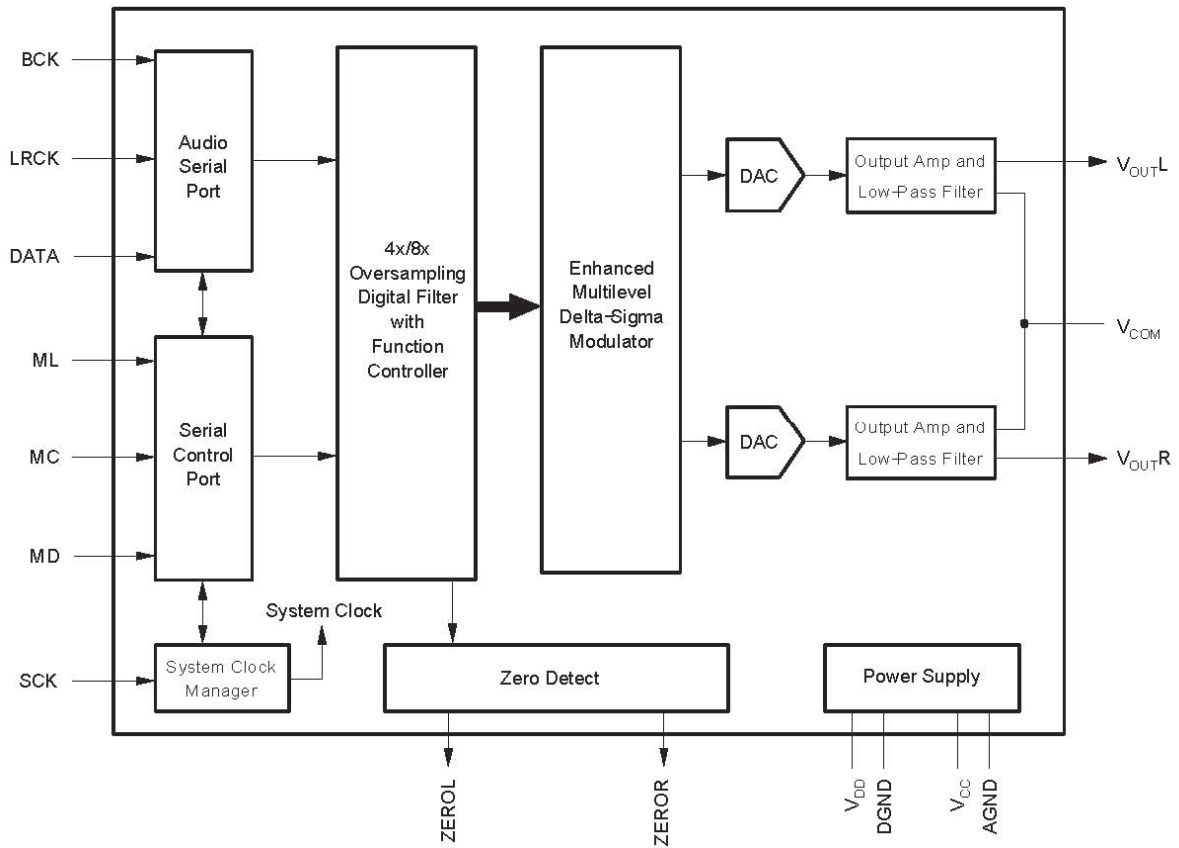

M61545
(U6002)

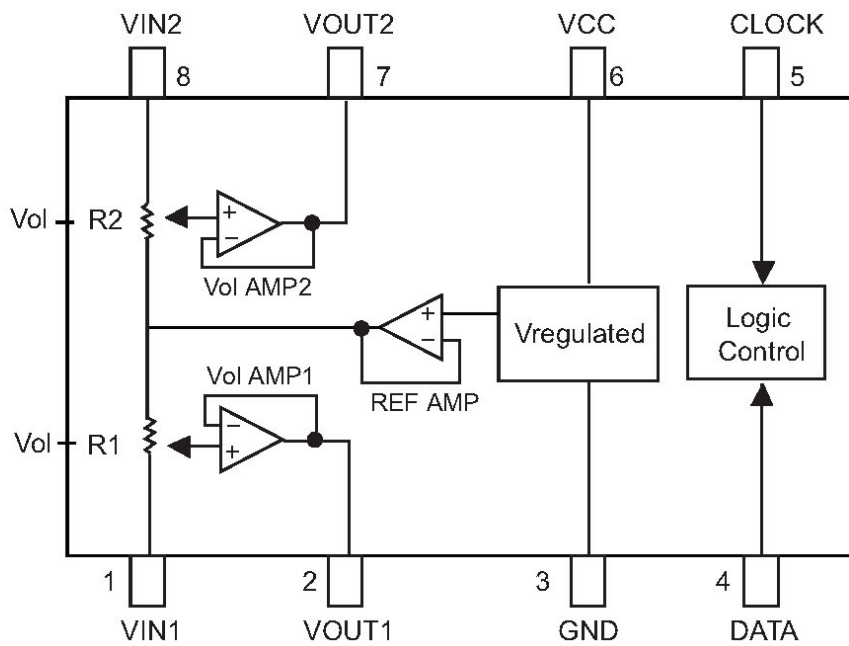

74HC157D
(U1033)

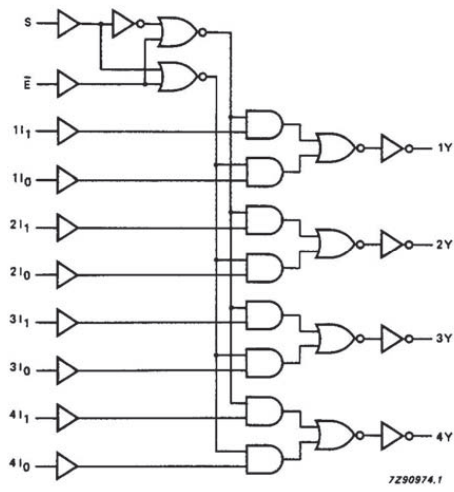

SST39VF800
(U1004)

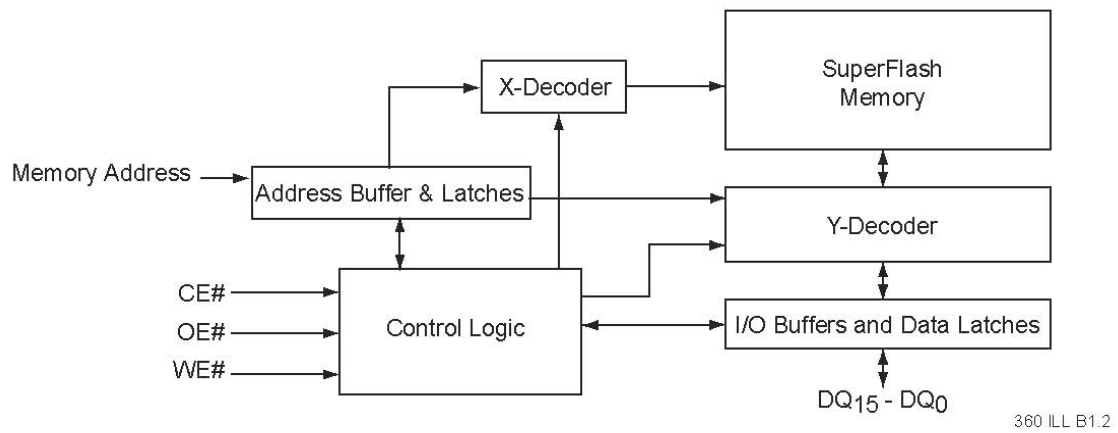

K4S641632K
(U1003)

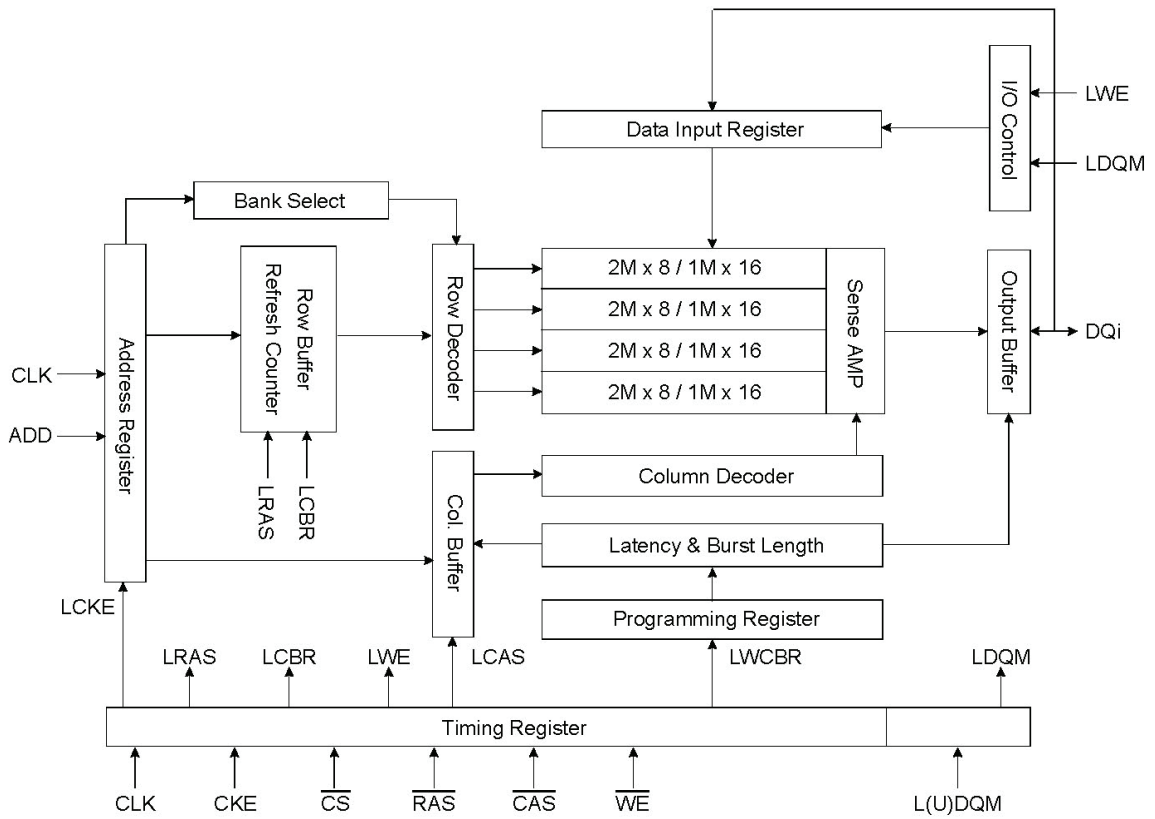

74HC251D
(U1005)

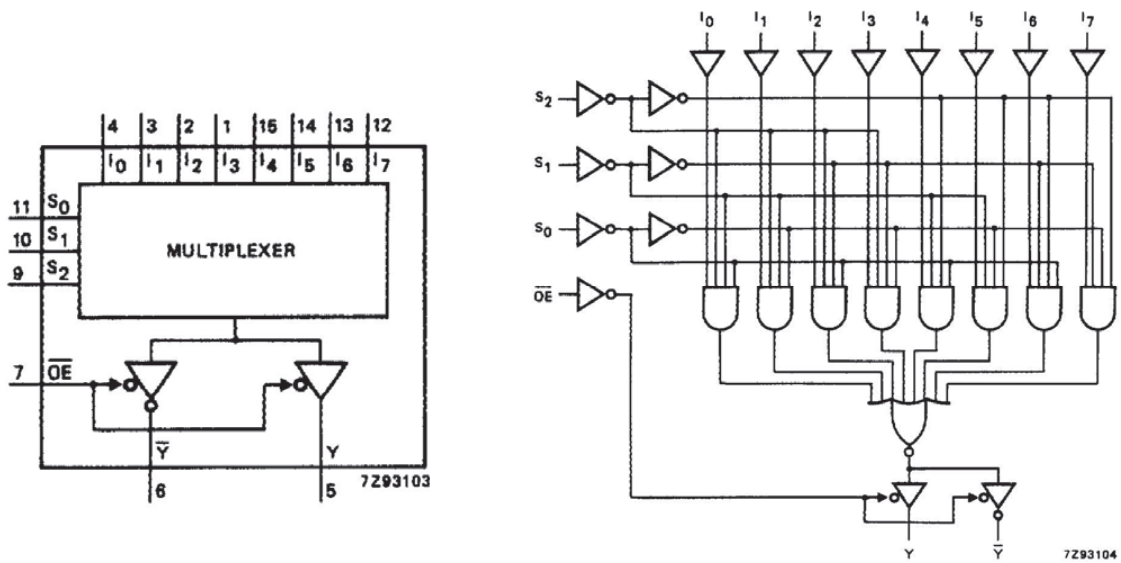

74HCU04D
(U1018, U1019)

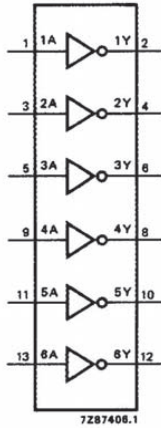

SN74LVCM245
(U1010, U1022 in DSP, U4518 in Component)

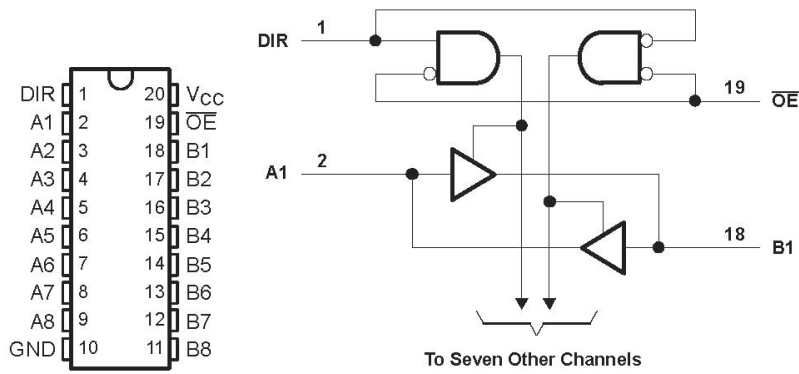

TL5001CD
(U1011)

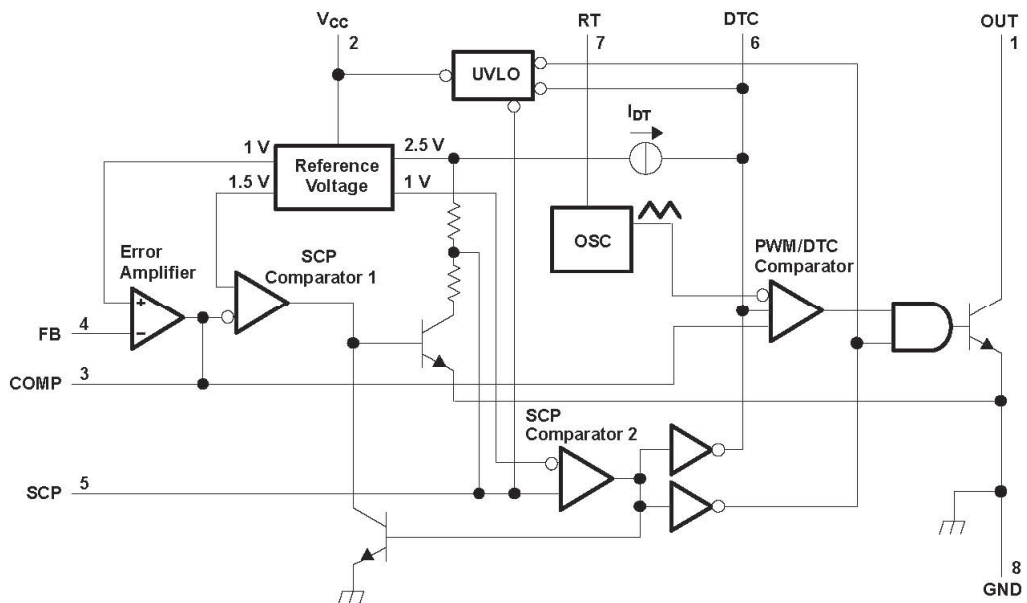

SN74HCT245
(U1009)

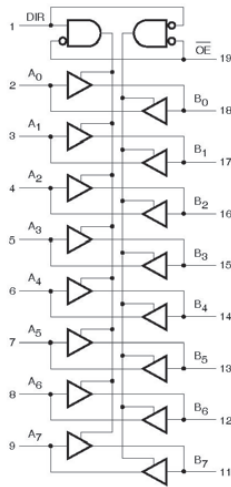

PCM1802
(U1017)

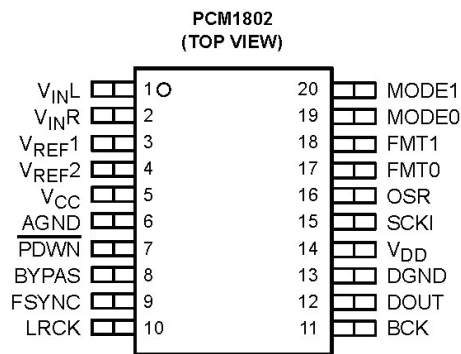

block diagram

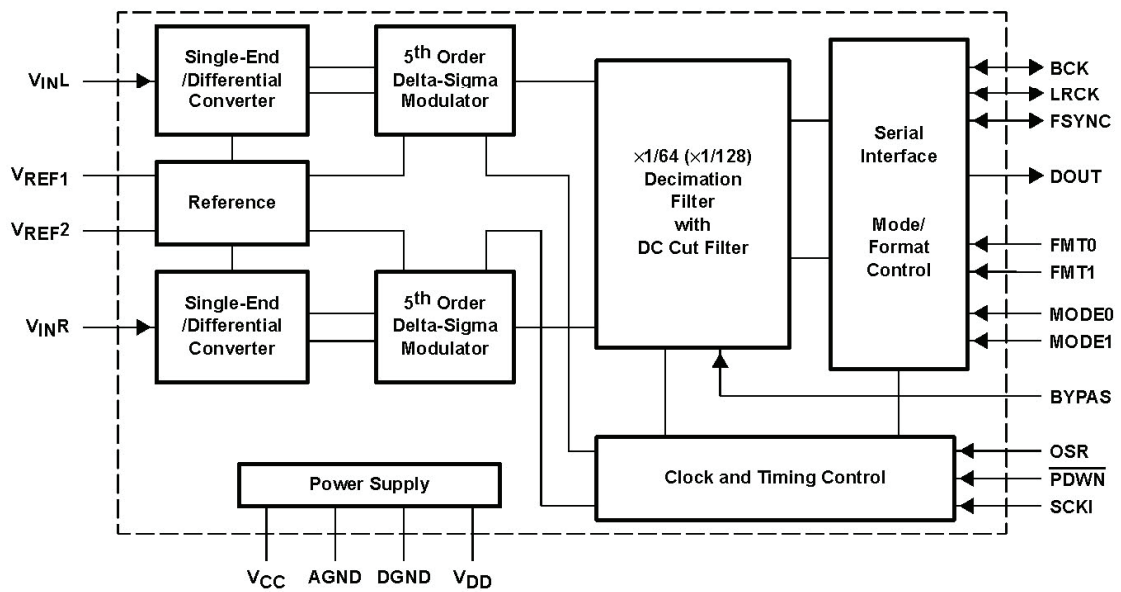

TPS3103
(U1021)

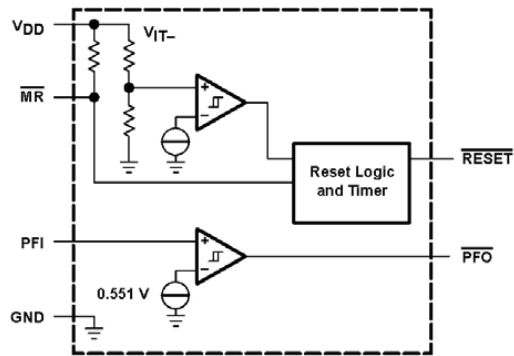
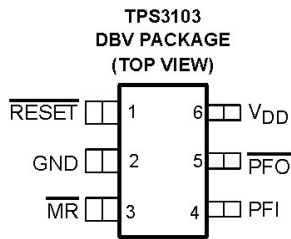

CS8416
(U1002)

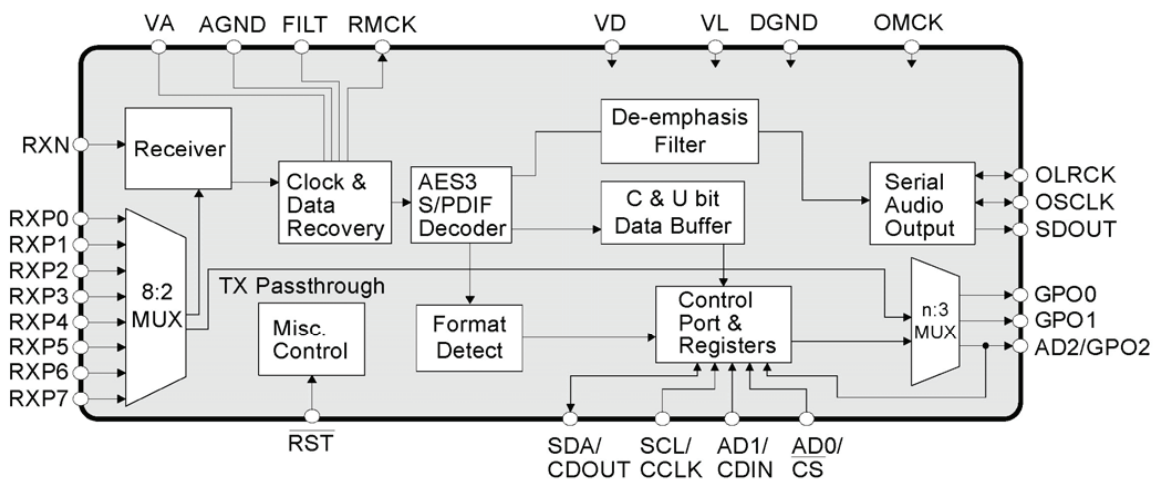
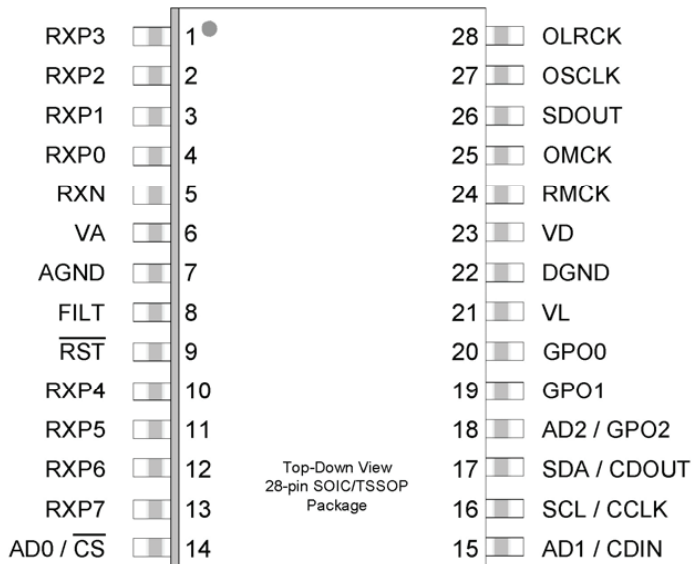

BU9450
(U1032)

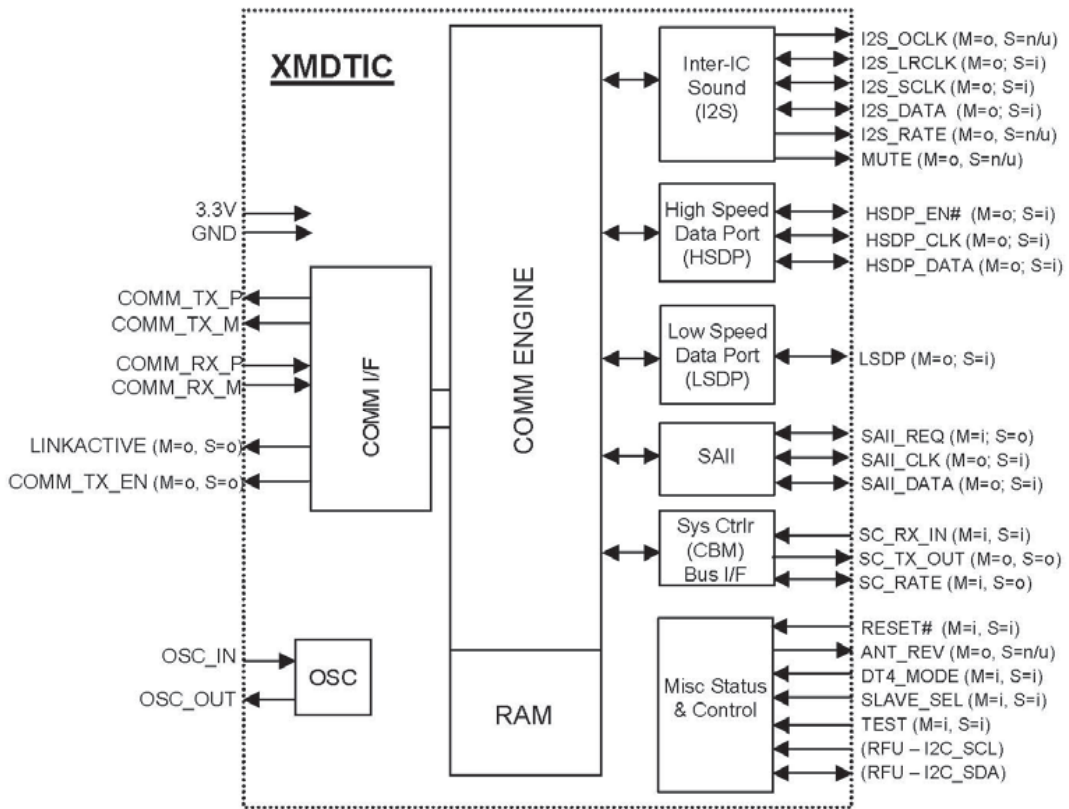

R2S15205FP
(U6001)

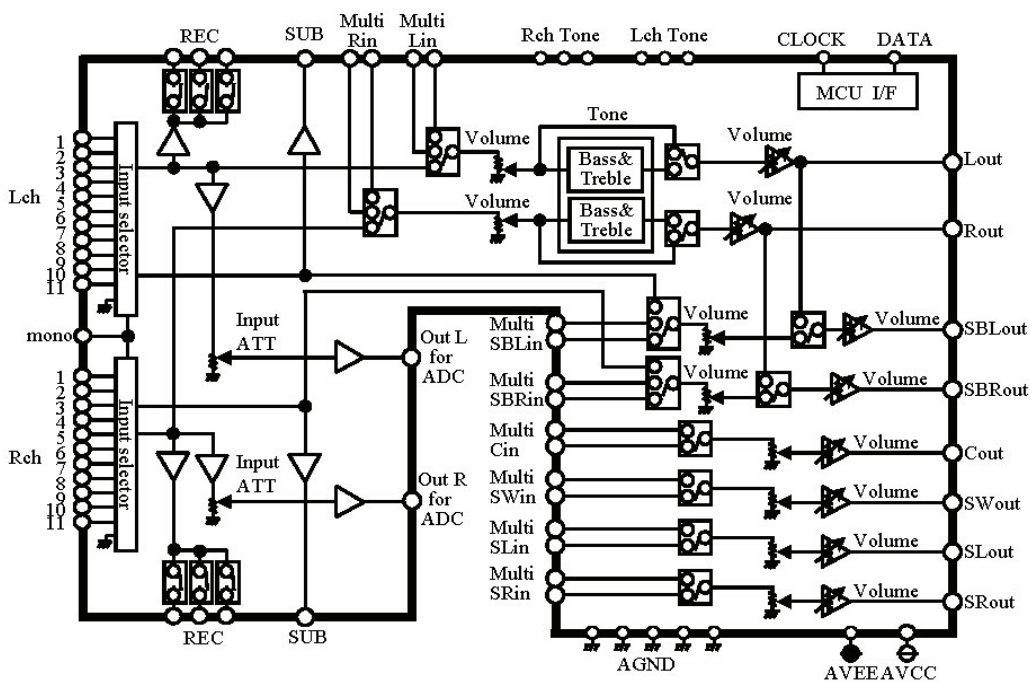

HDMI

CM1213-8

(D4301-4304 in HDMI, D2308 in Trigger)

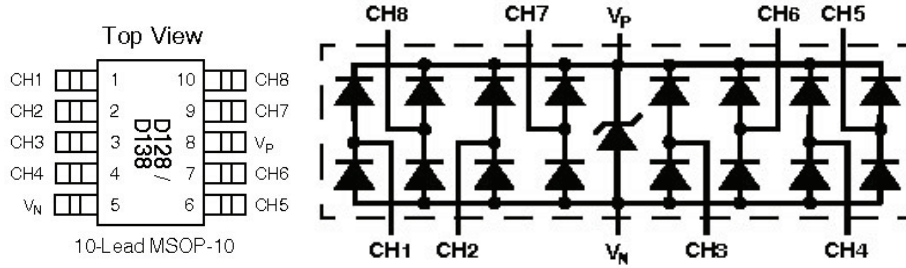

TMDS

(U15, U23)

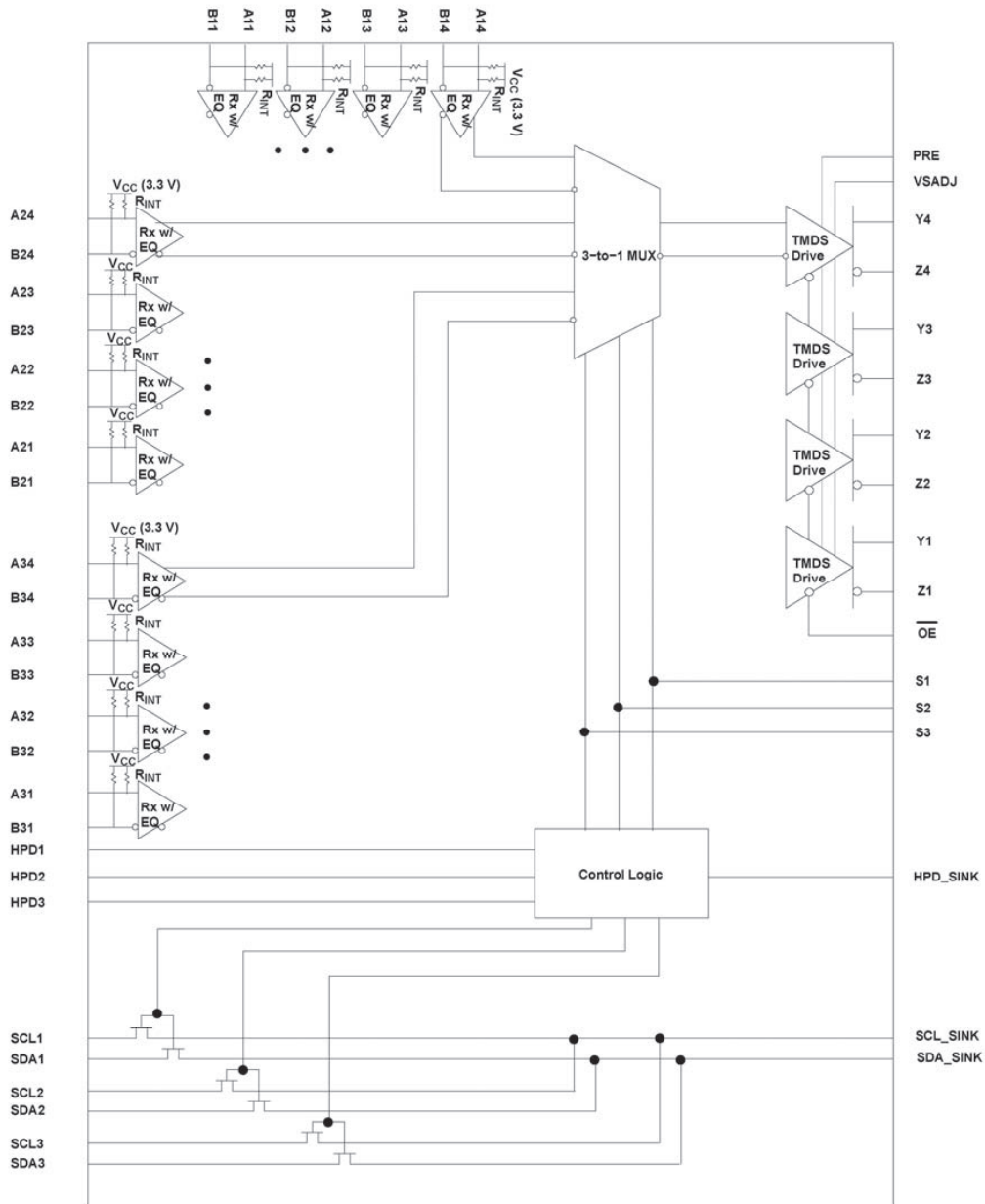

COMPONENT

ATtiny261

(U4520)

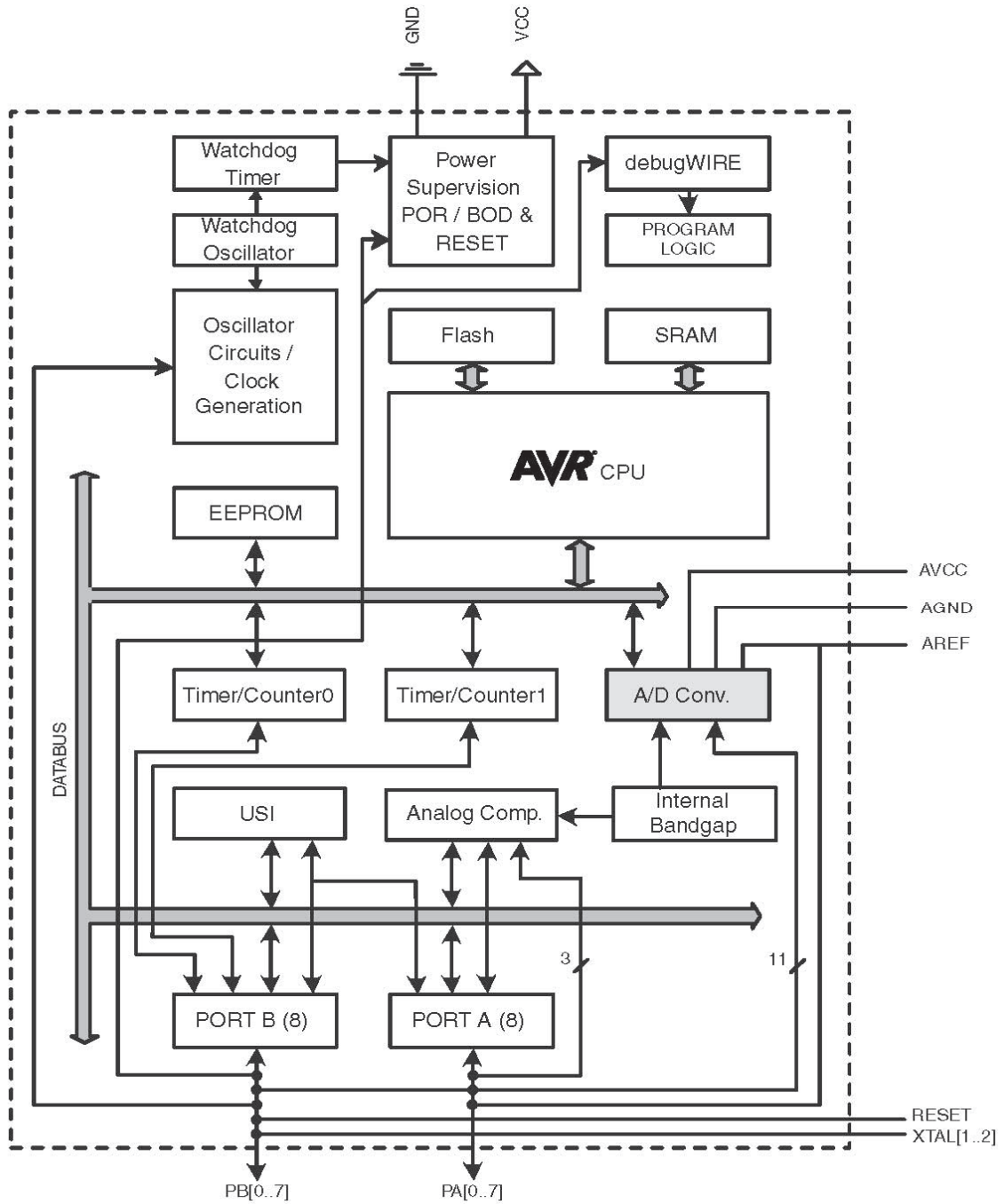

TVP5146PFP
(U4507)

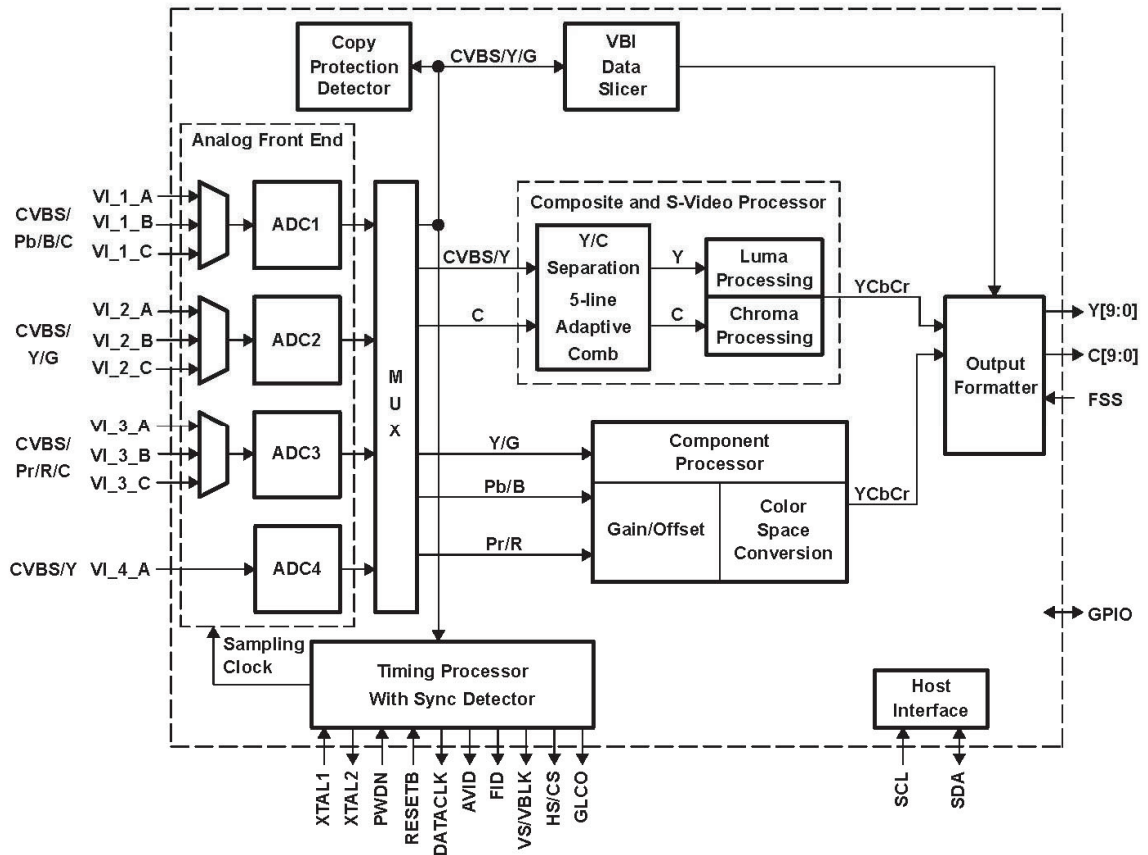

SAA7128
(U4508)

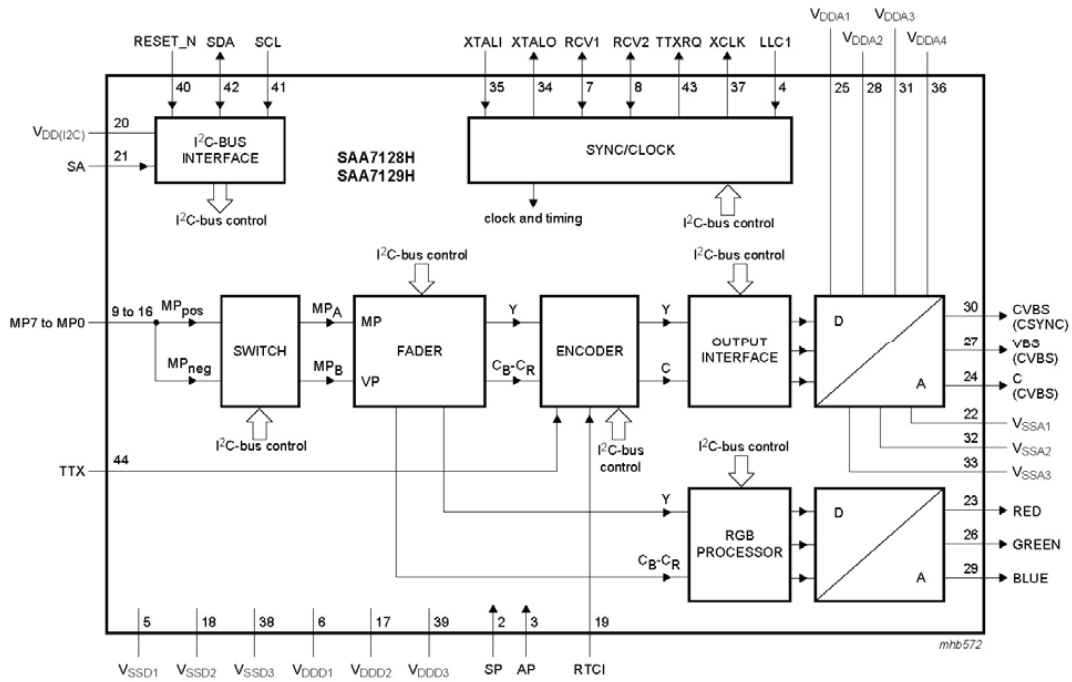

74HC4052D
(U4002-4003)

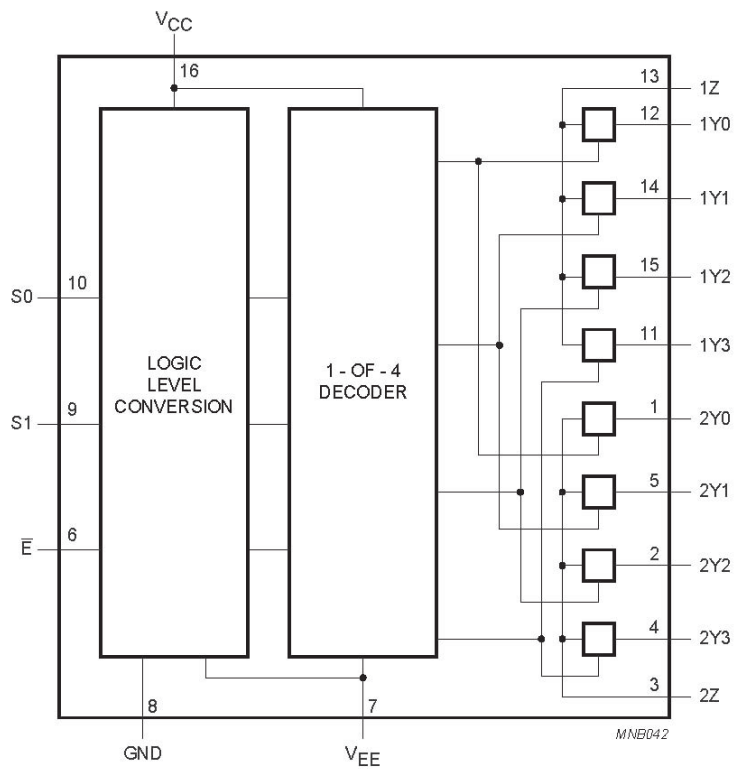

PCA9517
(U4513)

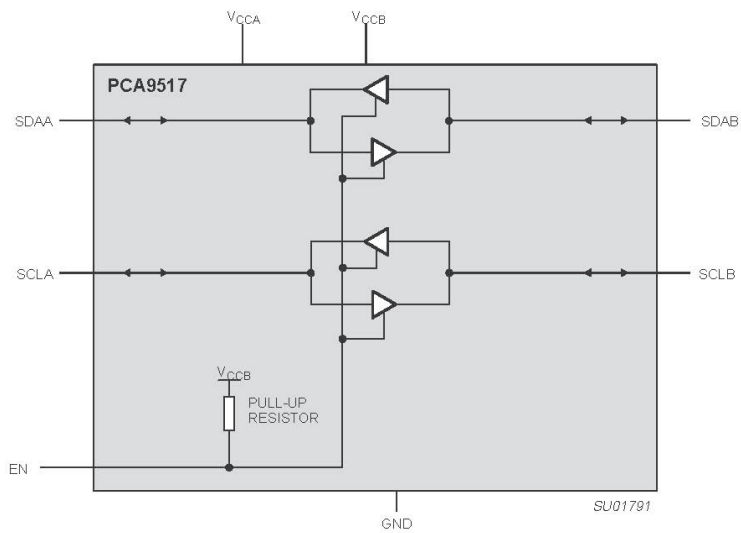
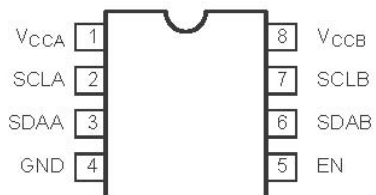

SN74AHCT244

(U4517)

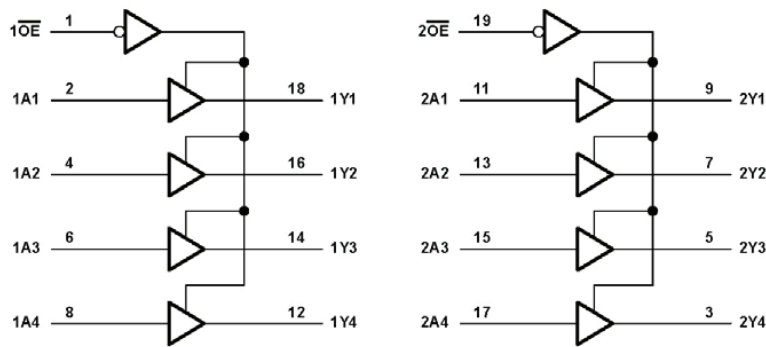

MC141585DW

(U19)

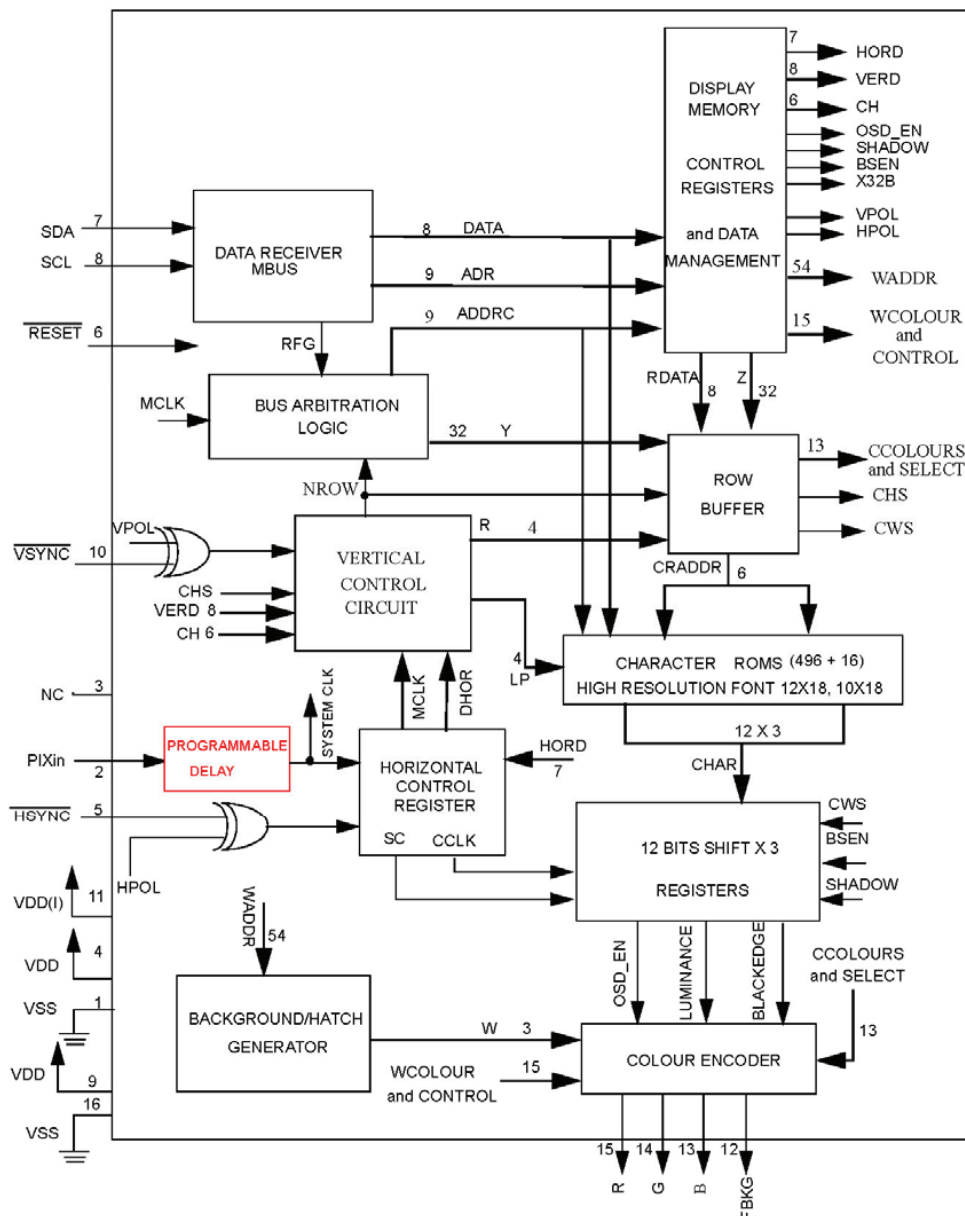

Trigger

74HC86D

(U2303)

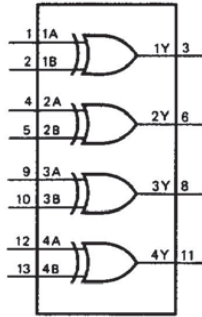

ST232BDR (U2301)

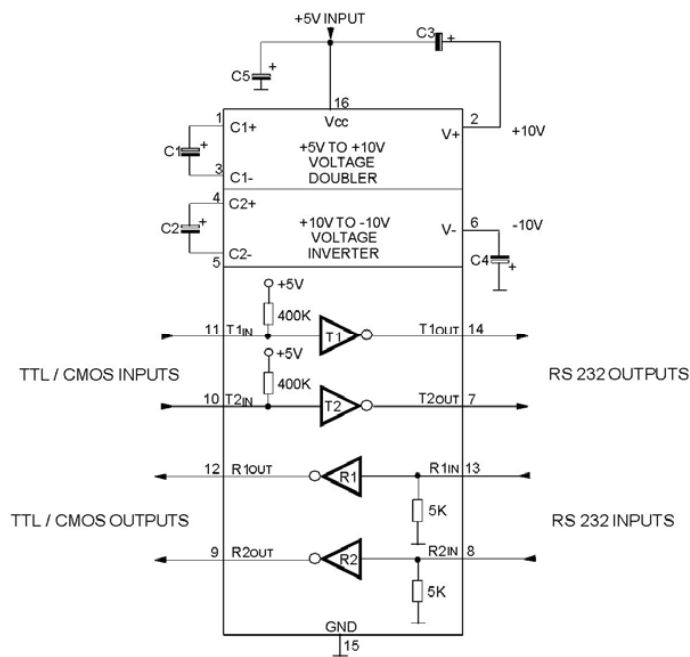

TPS2011A

(U2302)

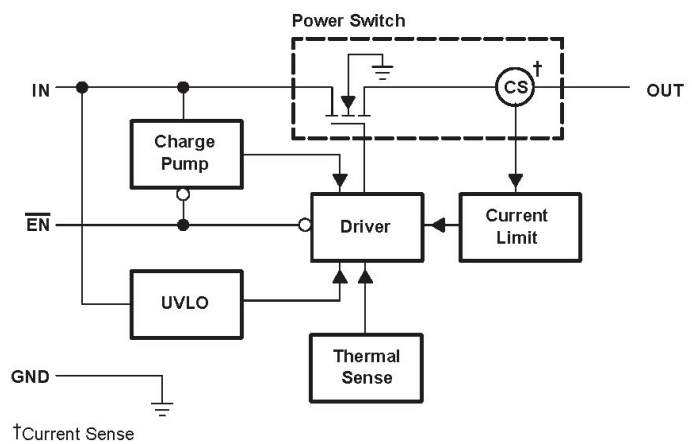
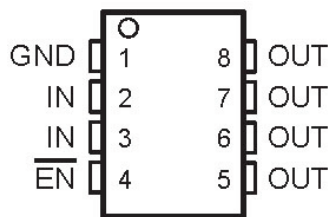

EXPLODED VIEW - A

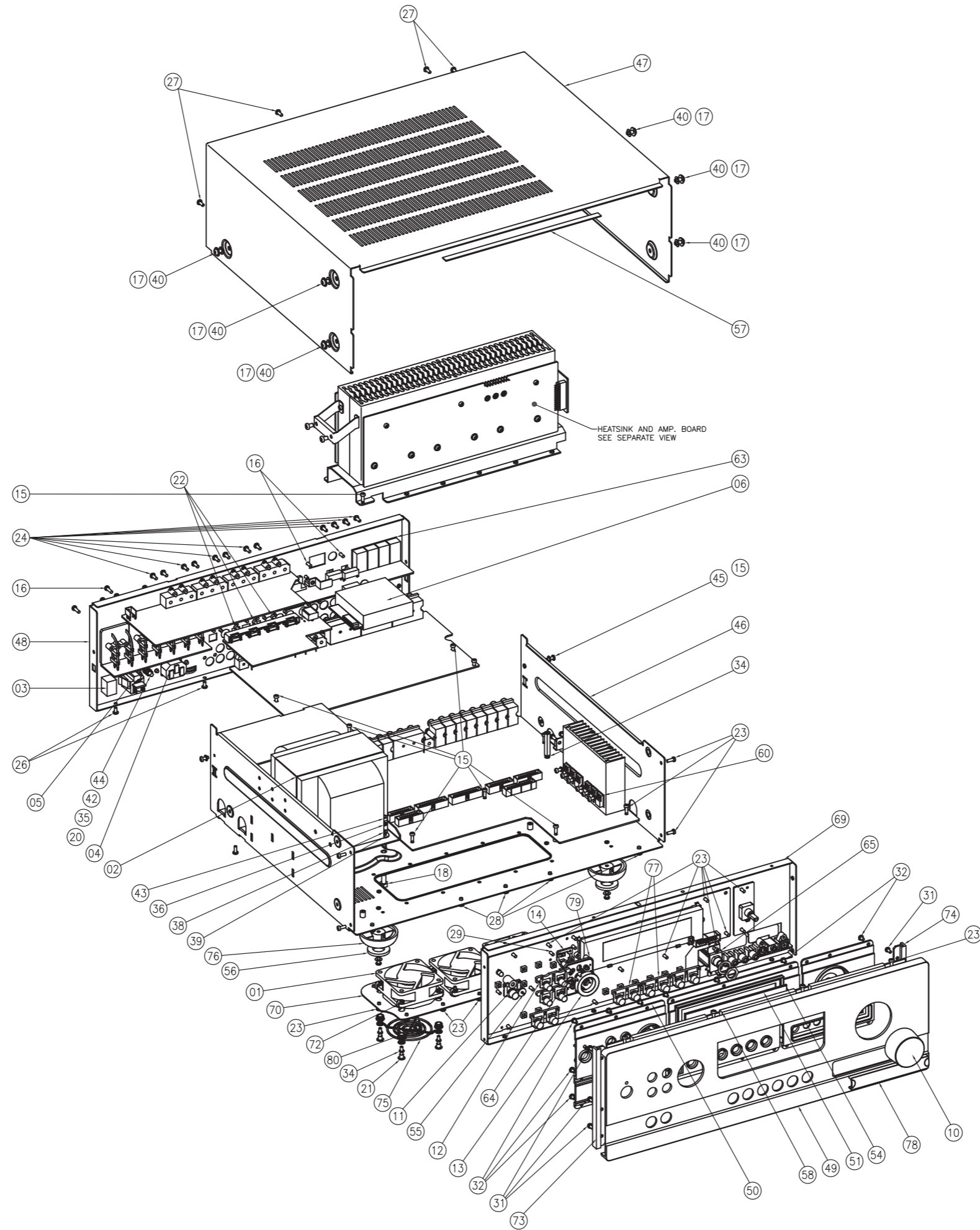

EXPLODED VIEW - B

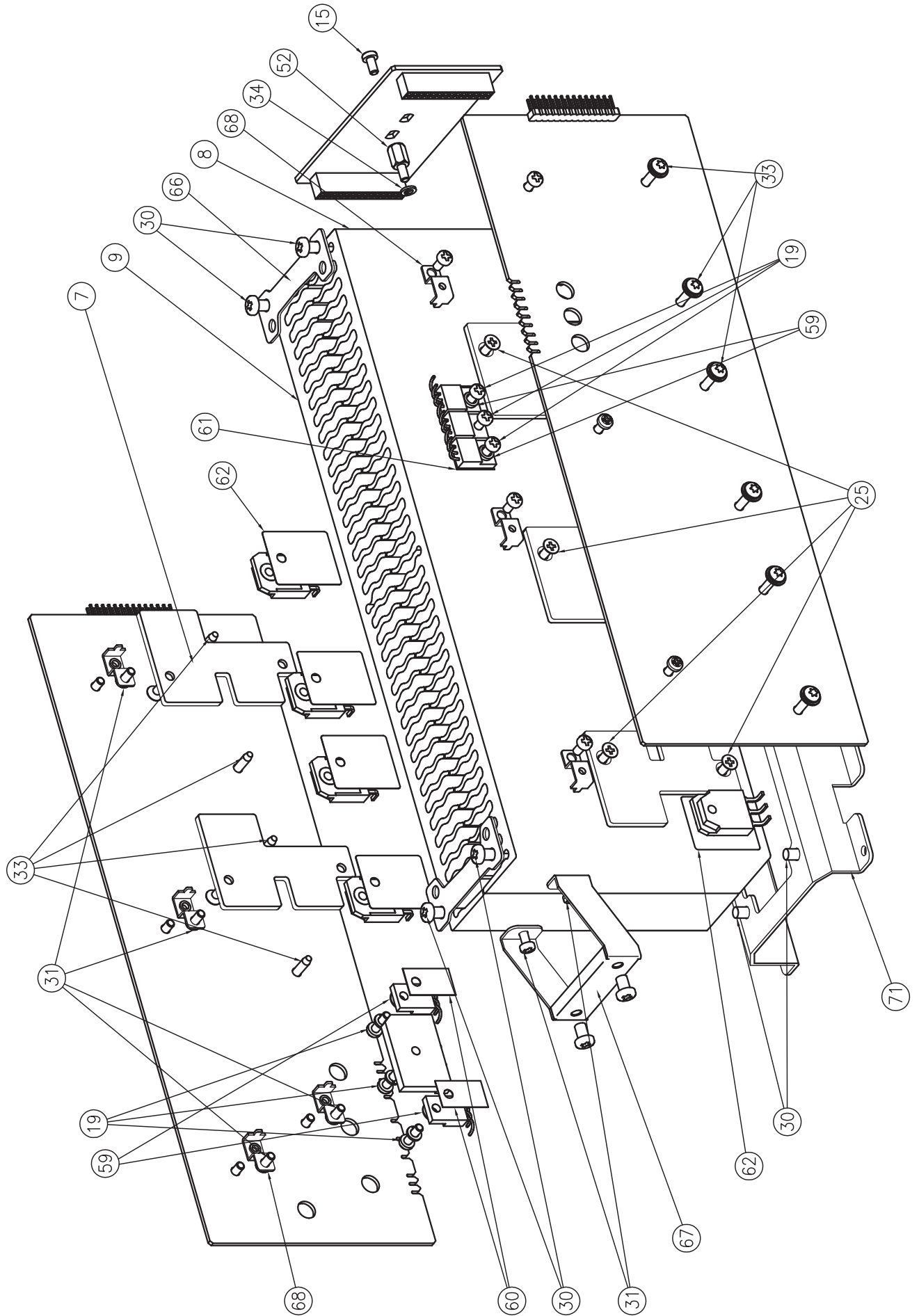

EXPLODED VIEW PARTS LIST

ITEM	PART NO.	DESC.	QTY
1	08-002-0067-90	FAN DC 60x20mm 12V 0.18A 3800RPM DF126020SL L=430mm w/ 2.5P CONNECTOR (RoHS)	3
2	10-005-0286-90	TRANSFORMER PW EI-114 120V T755 T08789A (RoHS) [FOR 120V VERSION]	1
	10-005-0287-90	TRANSFORMER PW EI-114 230V T755 T08789B (RoHS) [FOR 230V VERSION]	1
3	11-001-0062-90	SWITCH ROCKER 1P1T BLK/BLK 10A/250VAC TV-5 UL/CSA/VDE/SEMKO (RoHS)	1
4	15-004-0074-90	AC SOCKET IEC 10A 250V JR-101 (RoHS) [FOR 120V VERSION]	1
	15-004-0075-90	AC INLET 10A 250V R-301 RICH BAY UL/CCC/VDE/N/S (RoHS) [FOR 230V VERSION]	1
5	15-004-0078-90	AC OUTLET 3 PINS US POLARIZED SS-6B-1-NY (RoHS) [FOR 120V VERSION]	1
	15-004-0076-90	AC OUTLET EURO CEE 7 2.5A/250V A302D0060P (RoHS) [FOR 230V VERSION]	1
6	15-016-0001-90	AM/FM TUNER MIDULE KST-MB114MA0-23 (RoHS)	1
7	19-001-0116-90	HEATSINK PLATE TRANSISTOR 2.5MM ALUMINIUM (RoHS)	5
8	19-001-0124-90	EXT. HTSK FRONT T755 (RoHS)	1
9	19-001-0125-90	EXT. HTSK REAR T755 (RoHS)	1
10	21-001-0030-90	NEW VOLUME KNOB ASSY T175 GRAPHITE (RoHS) [FOR GRAPHITE VERSION]	1
	21-001-0031-90	NEW VOLUME KNOB ASSY T175 TITANIUM (RoHS) [FOR TITANIUM VERSION]	1
11	21-002-0155-90	POWER BUTTON TACT ACTIVE T765 GRAPHITE (RoHS) [FOR GRAPHITE VERSION]	1
	21-002-0156-90	POWER BUTTON TACT ACTIVE T765 TITANIUM (RoHS) [FOR TITANIUM VERSION]	1
12	21-002-0157-90	2X BUTTON SET T765 GRAPHITE (RoHS) [FOR GRAPHITE VERSION]	2
	21-002-0158-90	2X BUTTON SET T765 TITANIUM (RoHS) [FOR TITANIUM VERSION]	2
13	21-002-0159-90	4 WAYS BUTTON T765 GRAPHITE (RoHS) [FOR GRAPHITE VERSION]	1
	21-002-0160-90	4 WAYS BUTTON T765 TITANIUM (RoHS) [FOR TITANIUM VERSION]	1
14	21-002-0161-90	CENTER BUTTON T765 GRAPHITE (RoHS) [FOR GRAPHITE VERSION]	1
	21-002-0162-90	CENTER BUTTON T765 TITANIUM (RoHS) [FOR TITANIUM VERSION]	1
15	22-001-0367-00	SCREW MACHINE M3 x 6 P/H NI PLT (RoHS)	18
16	22-001-0376-90	MACHINE SCREW M3 x 6 P/H BLK (RoHS)	4
17	22-001-0379-90	MACHINE SCREW M4 x 8 WASHER HEAD BLK (RoHS)	6
18	22-001-0380-90	HEX HEAD SCREW M5 X 12 NI PLT	4
19	22-001-0381-90	MACHINE SCREW M3 x 10 PAN HEAD NI PLT (RoHS)	6
20	22-001-0384-90	MACHINE SCREW M4 x 14 WASHER HEAD BLK (RoHS)	1
21	22-001-0409-90	SCREW MACHINE M3 x 15 WASHER HEAD W/ STOPPER NI PLT (RoHS)	12
22	22-001-0410-90	SCREW MACHINE M2.6 X 6 K/H BLK PLT (RoHS)	3
23	22-003-0030-00	TAPTITE SCREW 3x8 P/H TYPE "B" ZN/NI PLT (RoHS)	47

24	22-003-0049-00	SCREW TAPTITE 3x8 B/H TYPE "B" BLK PLT (RoHS)	46
25	22-003-0129-00	SCREW TAPTITE 3x8 SMALL K/H TYPE "B" BLK PLT (RoHS)	12
26	22-003-0141-90	TAPTITE SCREW 3 X 6 B/H TYPE "B" BLK PLT (RoHS)	4
27	22-003-0143-90	TAPTITE SCREW 3.5 X 8.0 B/H TYPE "B" NI PLT (RoHS)	4
28	22-003-0144-90	TAPTITE SCREW 3.5x8 B/H TYPE "B" NI PLT (RoHS)	5
29	22-003-0145-90	SELF TAPPING SCREW 2.6x8 B/H TYPE "A" NI PLT (RoHS)	4
30	22-003-0147-90	TAPTITE SCREW 4 X 8 C/H TYPE-B BLK (RoHS)	12
31	22-003-0149-90	TAPTITE SCREW 3X6 PAN HEAD TYPE "B" NI PLT (RoHS)	20
32	22-003-0159-90	SCREW TAPTITE 3x5 B/H TYPE "B" NI PLT (RoHS)	22
33	22-003-0169-00	SCREW TAPTITE 3x15 B/H TYPE "B" CHROME TORX T10 W/ COMPRESS (RoHS)	10
34	22-005-0032-00	SPRING WASHER ID3.2 x OD5.6 x 0.9 THK. (RoHS)	15
35	22-005-0034-00	WASHER SPRING ID4 x OD7 x 1 THK. (RoHS)	2
36	22-005-0036-90	WASHER SPRING I/D 5.2 X O/D 8 X 1.2 THK ZINC PLT. (RoHS)	4
37	22-006-0081-00	WASHER STEEL ID3.5 x OD8 x 0.4 THK. ZN PLT (RoHS)	4
38	22-006-0085-90	WASHER STEEL I/D 5.6 X O/D 12 X 1 THK. NI PLT. (RoHS)	8
39	22-006-0089-00	WASHER METAL ID8.5 x OD16 x 1 NI PLT (RoHS)	4
40	22-006-0091-90	WASHER PVC ID4.2 x OD8.2 x 0.5mm (RoHS)	6
41	22-006-0117-00	COMPRESSION WASHER ID3.1 X OD7.7 X 1.2 THK CHROME PLT (RoHS)	10
42	22-007-0078-00	NUT M4 X 3.2mm 0.7p (RoHS)	2
43	22-007-0082-90	NUT M5 X 3.4 NI PLT (RoHS)	4
44	22-008-0025-00	WASHER OUTER TOOTH ID4.2xOD8.2x0.4 THK. NI PLT (RoHS)	1
45	22-008-0027-90	WASHER EXTERNAL TOOTH M3 ID3.2 x OD6.5x0.4 THK NI PLT (RoHS)	7
46	23-232-0024-90	BOTTOM CABINET T755 (RoHS)	1
47	23-236-0020-90	TOP COVER T755 (PAINTED PPG GREY) (RoHS) [FOR GRAPHITE VERSION]	1
	23-236-0021-90	TOP COVER T755 (PAINTED NAD SILVER) (RoHS) [FOR TITANIUM VERSION]	1
48	23-237-0034-90	REAR PANEL T755 (AH) (RoHS) [FOR 120V VERSION]	1
	23-237-0035-90	REAR PANEL T755 (C) (RoHS) [FOR 230V VERSION]	1
49	23-237-0045-90	FASCIA T755 GRAPHITE (RoHS) [FOR GRAPHITE VERSION]	1
	23-237-0062-90	FASCIA T755 TITANIUM (RoHS) [FOR TITANIUM VERSION]	1
50	23-237-0051-93	PLASTIC INNER PANEL T765 GRAPHITE (RoHS) R2 [FOR GRAPHITE VERSION]	1
	23-237-0052-93	PLASTIC INNER PANEL T765 TITANIUM (RoHS) R2 [FOR TITANIUM VERSION]	1
51	24-031-0007-90	STATIC COVER T775 (PET)(RoHS)	1
52	25-005-0118-90	HEX SPACER AF5.5 H8+6 (RoHS)	1
53	25-005-0121-90	HEX SPACER AF5.5 F/F H29.4 (RoHS)	2

54	25-008-0404-90	FRONT LENS TINT COLOR TXX5 AH (RoHS) [FOR 120V VERSION]	1
	25-008-0405-90	FRONT LENS TINT COLOR TXX5 CE (RoHS) [FOR 230V VERSION]	1
55	25-008-0409-90	POWER LED LENS - ROUND #2 MILKY WHITE (RoHS)	1
56	25-014-0030-90	RUBBER FOOT I/D14 X O/D26 X 3 PORON HH-48C (RoHS)	4
57	25-016-0025-90	FOAM 9 X 240 X 1.5mm BLACK (UL GRADE) W/NITTO 500 (RoHS)	1
58	25-016-0033-90	FOAM 100x7x8mm BLACK (UL GRADE) W/ NITTO 500 (RoHS)	3
59	25-017-0265-90	STANDARD BUSHING TO-220 NATURAL R.0	4
60	25-020-0338-00	SILICONE RUBBER INSULATOR L18 X W13 X T0.3 W/HOLE (RoHS)	8
61	25-020-0344-90	SILICONE RUBBER INSULATOR L18 X W11.5 W/HOLE (RoHS)	2
62	25-020-0475-90	INSULATOR TO-3P MICA 22x27x0.125mm W/ HOLE (RoHS)	10
63	25-020-0488-90	INSULATOR 57x17x0.3mm PVC BLACK (RoHS)	1
64	25-021-0004-90	RUBBER KEYPAD TXX5 (RoHS)	1
65	25-022-1248-90	PHONE BRACKET T775 (RoHS)	1
66	25-022-1250-90	HTSK HANDLE PLATE (RoHS)	2
67	25-022-1254-90	HTSK SUPPORT BRACKET (RoHS)	1
68	25-022-1326-90	SPACER BRACKET 5.0mm (RoHS)	7
69	25-022-1338-90	SUBFASCIA T755 (RoHS)	1
70	25-022-1339-90	FAN BRACKET PLATE T755 (RoHS)	1
71	25-022-1340-90	HTSK BRACKET T755 (RoHS)	1
72	25-022-1341-90	FAN SCREW BRACKET 4.5mm (RoHS)	12
73	25-022-1342-90	SIDE CAP - L T755 GRAPHITE (RoHS) [FOR GRAPHITE VERSION]	1
	25-022-1624-90	SIDE CAP - L T755 (PAINTED NEW TITANIUM) (RoHS) [FOR TITANIUM VERSION]"	1
74	25-022-1343-90	SIDE CAP - R T755 GRAPHITE (RoHS) [FOR GRAPHITE VERSION]	1
	25-022-1625-90	SIDE CAP - R T755 (PAINTED NEW TITANIUM) (RoHS) [FOR TITANIUM VERSION]	1
75	25-022-1381-90	FAN GUARD 60mm 40G00002 (RoHS)	3
76	25-024-0315-90	PLASTIC FOOT DOME SHAPE (RoHS)	4
77	25-024-0322-90	DUAL BUTTON T765 GRAPHITE (RoHS) [FOR GRAPHITE VERSION]	4
	25-024-0323-90	DUAL BUTTON T765 (PAINETED TITANIUM) (RoHS) [FOR TITANIUM VERSION]	4
78	25-024-0324-90	VIDEO COVER T765 GRAPHITE (RoHS) [FOR GRAPHITE VERSION]	1
	25-024-0325-90	VIDEO COVER T765 (PAINETED TITANIUM) (RoHS) [FOR TITANIUM VERSION]	1
79	25-024-0326-90	RUBBER BRACKET T765 (MOLDED BLACK) (RoHS)	1
80	25-024-0330-90	FAN RUBBER (RoHS)	12

Enlarged in detail on the next page

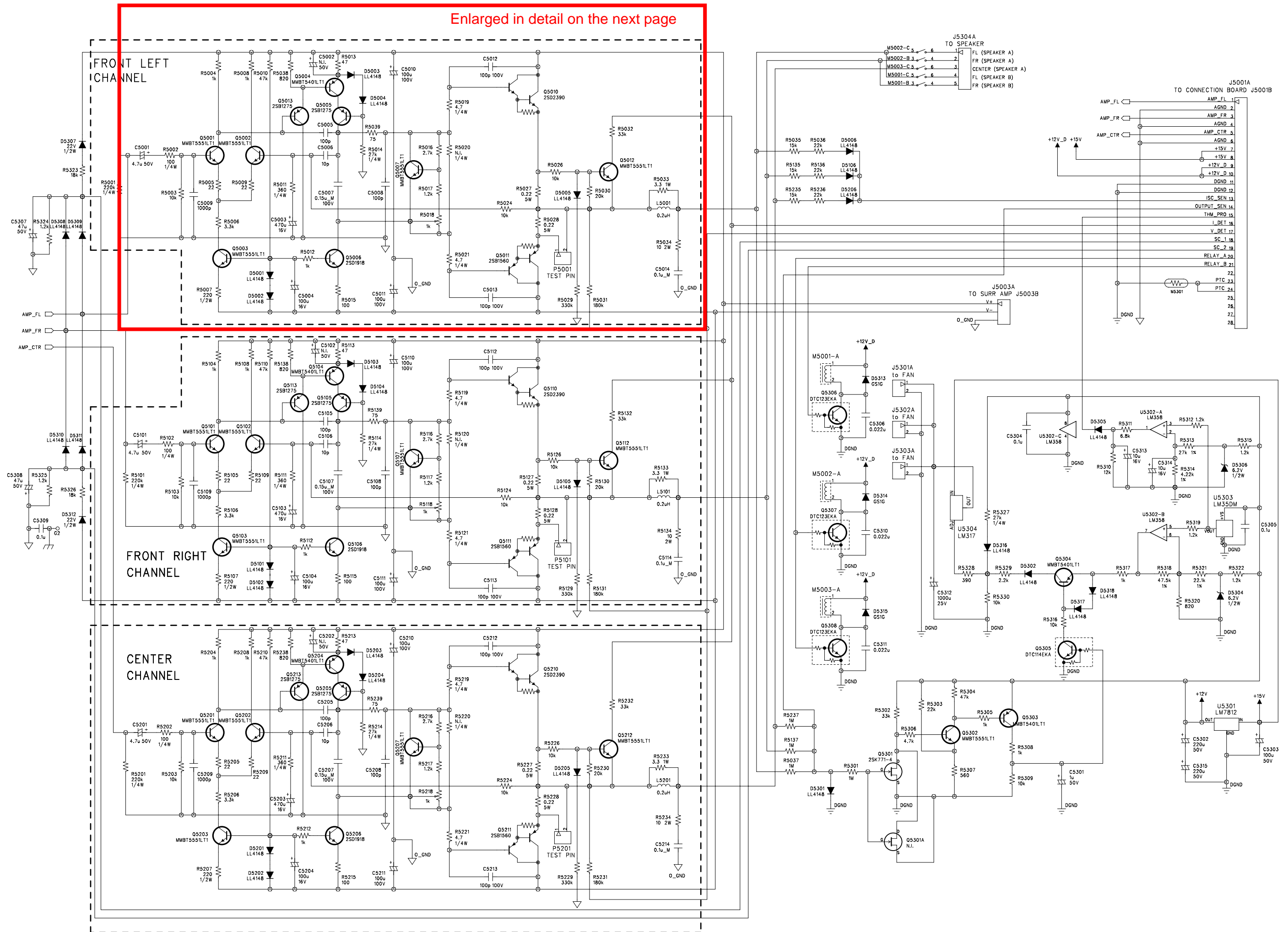

SINGLE AMPLIFIER CHANNEL REPAIR KIT

Components in the red boxes are included in the single amplifier repair kit.
Part number 52-940-0755-90

T755 Power amplifier components (single channel)		
Part Number	Description	Qty
02-005-0063-90	RES WW 0.22 OHM 5% 5W	2
02-007-0314-90	RES SMD 220 OHM 5% 1/2W	1
03-009-0144-90	CAP ELEC SMD 470uF 16V +/-20%	1
03-009-0152-90	SMD E CAP 100uF/16V ±20% LOW IMPEDANCED	1
03-009-0192-90	CAP ELEC SMD 4.7uF 50V +/-20%	1
04-006-0021-90	SMD DIODE LL4148 SOD80	5
05-001-0100-90	TRANSISTOR PW DARLINGTON PNP 10A/150V HFE P 6500-20000 TO-3PB 2SB1560 (w/ MICAx1)	1
05-001-0101-90	TRANSISTOR PW DARLINGTON NPN 10A/150V HFE P 6500-20000 TO-3PB 2SD2390 (w/ MICAx1)	1
05-004-0018-90	SMD Transistor MMBT5551LT1G NPN SOT-23	5
05-004-0019-90	SMD Transistor MMBT5401LT1G PNP SOT-23	1
05-004-0030-90	XTR 2SD1918 NPN POWER 160V/1.5A 80MHz HFE 120-390	1
05-004-0031-90	XTR 2SB1275 PNP POWER 160V/1.5A 50MHz HFE 82-180	2

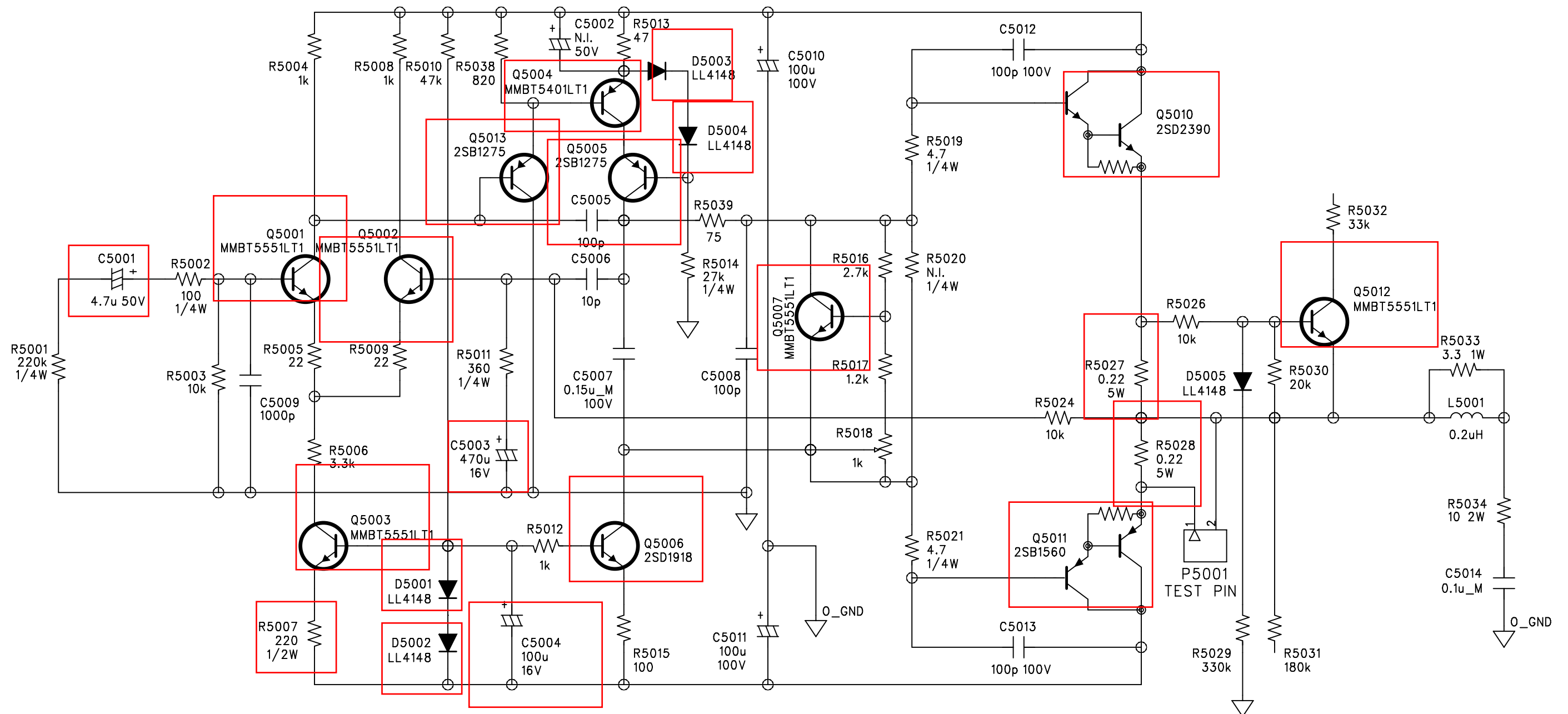

PACKING DIAGRAM & PARTS LIST

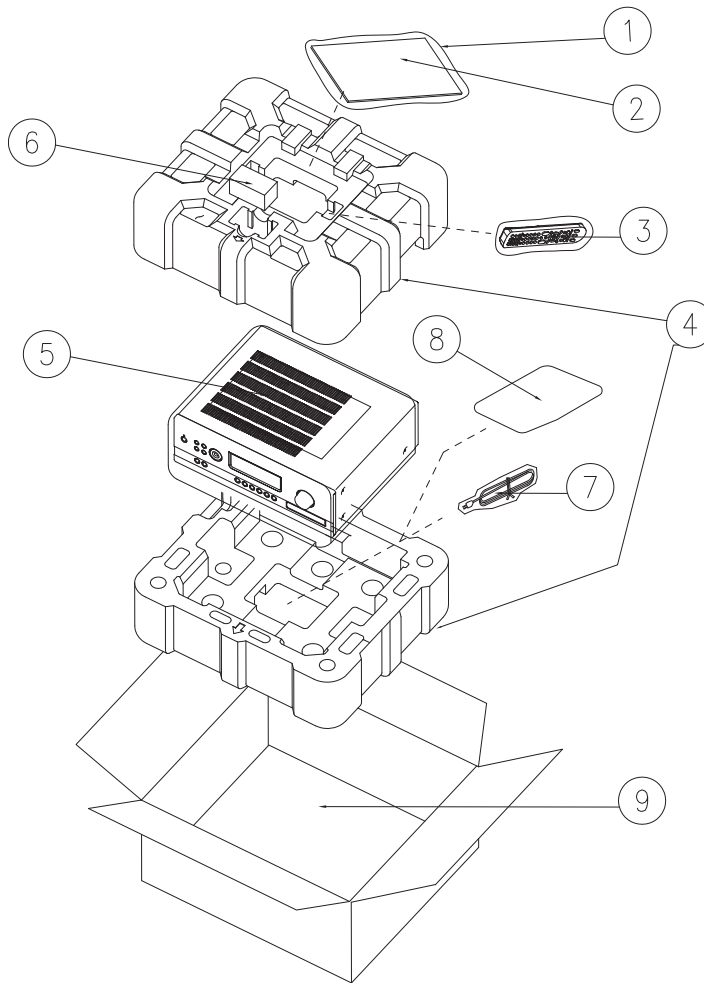

ITEM	PART NO.	DESCRIPTION	QTY
1	24-003-0127-90	POLYBAG MAUNAL (RoHS)	
2	24-004-2012-90	T755 OWNER'S MANUAL GB/F/D/NL W/WEEE	1
2	24-004-2013-90	T755 OWNER'S MANUAL E/I/P/S W/WEEE	1
2	24-004-2227-90	T755 QUICK START MANUAL A3 SIZE (RoHS)	1
2	24-004-1936-90	WARRANTY CARD (RoHS)	1
3	28-008-0004-92	REMOTE CONTROLLER NAD HTR-3 (RoHS)	1
4	24-006-0776-90	POLYFOAM TOP/BOTTOM T755(ROHS)	2
5	24-003-0130-90	POLYBAG T762 W/SILKSCREEN MAIN UNIT	1
5	24-003-0134-90	PROTECTIVE COVER T755 (RoHS)	1
5	24-005-0890-90	A3 WHITE PAPER 80G (RoHS)	1
5	40-001-0108-90	DESSICANT BAG 20g	1
6	09-001-0005-90	MICROPHONE SET WITH PACKING AUDYSSEY(RoHS)	1
7	17-004-0007-00	AC Cord 110V 3PINS 125V/13A SJT AWG16/3C UL/CSA L=2M [FOR AH VERSION]	1
	17-004-0008-00	AC CORD CE 3 PINS 16A 250V LF L=6'7" LP-34 H05VV-F 3C LS- 60 [FOR C, CT VERSION]	1
7	24-003-0120-90	POLYBAG CORD (RoHS)	1
8	15-015-0001-90	ANTENNA ADAPTER 300 TO 75 OHM (RoHS)	1
8	24-003-0122-90	Polybag Manual J9 (RoHS)	1
8	25-027-0001-90	FM WIRE ANTENNA W/Y-TERMINALS (RoHS)	1
8	25-027-0002-90	ANTENNA AM LOOP ASSY W/STAND S0160BL-04 (RoHS)	1
8	28-008-0005-90	REMOTE CONTROLLER NAD ZR-4 (RoHS)	1
9	24-001-0665-90	MASTER CARTON BOX T755 (ROHS)	1